

CUTTING • WELDING • BRAZING



In the photo: Svetlana Melnik, Senior packer; Vladimir Tsvetukh, Welding specialist; Arina Alekseyenko, Engineer



Made in Ukraine

CE  
2025

AUTOGENOUS EQUIPMENT PLANT [®]
 **DONMET**



Team DONMET 01.10.2021

CONTENTS

"MICRO" SERIES	1
CUTTING TORCHES	5
MACHINE CUTTING TORCHES	16
FLUX CUTTING SET	17
ACETYLENE TORCHES FOR WELDING	18
PROPANE TORCHES FOR BRAZING	20
GAS TORCHES FOR HEATING	21
AIR-GAS TORCHES	23
AIR TORCHES WITH FORCED AIR SUPPLY	27
FLASHBACK ARRESTORS	30
PRESSURE REGULATORS	32
OPTIMIZER DM	48
SPECIAL PRESSURE REGULATORS	49



*Dear friends!
Thank you for your kind attention
to our company!
I guarantee the quality
of the products.*

*Sincerely yours,
Director of "Donmet plant"
Volodymyr Sergiyenko*



Cutting torch | "DONMET" 132P MICRO | Palnik do cięcia

THE LIGHTEST AND SMALLEST GAS CUTTING TORCH

- a perfect alternative to a standard cutting torch when cutting metal up to 20mm thick
- cost-effective: oxygen consumption 3 times lower than that of standard cutting torches
- for performing fine high-precision cuts and working in hard-to-reach places
- no submelting or warping of thin metal
- light-weight and small-size: can be combined with portable gas kits

THE LIGHTEST AND SMALLEST GAS CUTTING TORCH ON THE MARKET



NO ANALOGUES IN THE WORLD!

Spare brazing tip (optional)

No. 132.600.00



PROPANE



Cutting nozzle	1-20 mm	132.303.00
Preheating nozzle		132.302.00
Cutting tip for 132P		132.300.00

NAJLŹEJSZY WYGODNY PALNIK DO CIĘCIA

- alternatywa dla standardowych palników podczas cięcia stali do 20mm
- ekonomiczne: zużycie tlenu jest 3 razy mniejsze niż w standardowych palnikach
- Do precyzyjnego cięcia i do trudno dostępnych miejsc
- nie topi metal przy jego małej grubości
- najlżejszy i wygodny: najlepszy do zestawu montażowego spawacza

BRAK ANALOGÓW NA ŚWIECIE!

Ø6mm and Ø8mm

a) Supplied with hoses 3,2mm in diameter and 1,5m long

b) Supplied with nipples Ø6

Item	Order No.
a) "DONMET" 132P MICRO with hoses	132.000.01
b) "DONMET" 132P MICRO with nipples	132.000.03

Cutting torch | "DONMET" 132A MICRO | Palnik do cięcia

THE LIGHTEST AND SMALLEST GAS CUTTING TORCH ON THE MARKET NO ANALOGUES IN THE WORLD!

Cutting + welding: the smallest and lightest acetylene cutting torch with replaceable drawn copper welding tip No. 3A.

- Light-weight, small-size and cost-efficient.
- Cutting capacity up to 20mm.
- Cutting and welding in hard-to-reach places.
- Perfect curvilinear cuts.
- Consumes 3 times less oxygen than any other cutting torch.
- 300g in weight and no more than 290mm in length.



ACETYLENE



Spare parts (as per customer's order)

Cutting nozzle for 132A Micro (1-20mm)	132.303.02
Preheating nozzle for 132A Micro	132.302.02
Welding tip	132.600.01
Cutting tip for DONMET 132A	132.300.01

BRAK ANALOGÓW NA ŚWIECIE!

Cięcie + spawanie: najmniejszy i najlżejszy palnik do cięcia acetylenem z wymienną wyciągniętą miedzianą końcówką spawalniczą nr 3A.

- Lekki, mały i ekonomiczny.
- Wydajność cięcia do 20 mm.
- Cięcie i spawanie w trudno dostępnych miejscach.
- Idealne cięcia krzywoliniowe.
- Zużywa 3 razy mniej tlenu niż jakiegokolwiek inny palnik do cięcia.
- 300 g wagi i nie więcej niż 290 mm długości.

Supplied with hoses 3,2mm in diameter and 1,5m long

Ø6mm and Ø8mm

Item	Order No.
"DONMET" 132A MICRO	132.000.11

Brazing torch | "DONMET" 284 MICRO | Palnik

PROPANE-BUTANE (methane, MAPP) + OXYGEN

FLAME TEMPERATURE 2400-2500°C



- miniature cost-effective torch for fine brazing with hard solders in the medium of oxy-propane flame. Can be used for brazing copper tubes, refrigeration and air-conditioning systems, etc.
- can be combined with portable gas kits
- light weight and maximum mobility due to flexible gas hoses Ø3.5mm



PROPAN-BUTAN (gaz ziemny, MAF) + TLEN

TEMPERATURA PŁOMIENIU 2400-2500°C



- miniaturowy i ekonomiczny palnik do precyzyjnego lutowania twardym lutem do rur miedzianych, elementów systemów chłodniczych, klimatyzacyjnych itp.
- najlepszy do zestawu montażowego spawacza
- ma niską masę i maksymalną zwrotność dzięki węzom gazowym Ø3.5mm

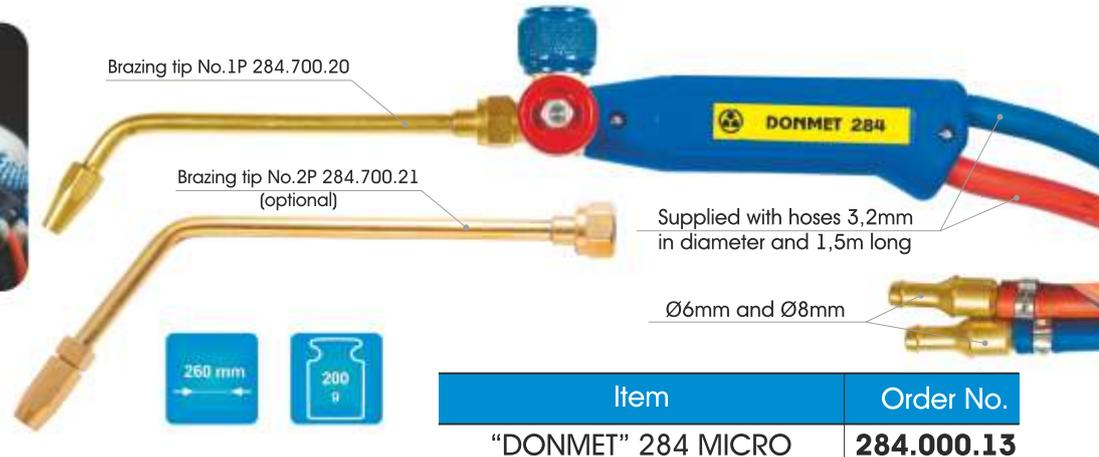

MICRO-series pressure regulators | Regulatory ciśnienia serii MICRO



- Used for disposable steel cylinders filled with oxygen or propane. Pressure regulator MICRO DM with thread M12x1 can fit 1-litre oxygen cylinders produced by "Oxyturbo", "Providus", "Castolin Eutectic".
- Pressure regulator MICRO DM with thread M10x1 can fit oxygen 1L cylinders produced by "Kemper"
- Internal check valve for safe operation
- Knob coloured according to gas type

- ▶ Hose barbs Ø3.2-3.5
- ▶ MICRO-series nipples
- ▶ Used for disconnecting adaptors from hose Ø3.2mm to hose Ø6mm or Ø9mm



- Stosowany do jednorazowych stalowych butli wypełnionych tlenem lub propanem. Regulator ciśnienia MICRO DM z gwintem M12x1 może pasować do 1-litrowych butli tlenowych produkowanych przez "Oxyturbo", "Providus", "Castolin Eutectic".
- Regulator ciśnienia MICRO DM z gwintem M10x1 pasuje do butli tlenowych 1L produkowanych przez "Kemper"
- Wewnętrzny zawór zwrotny zapewniający bezpieczną pracę
- Pokrętko kolorowe w zależności od rodzaju gazu

- ▶ Złączki Ø3,2-Ø3,5
- ▶ Złączki serii MICRO
- ▶ Służą do podłączania adapterów z węży Ø3.2mm do węży Ø6mm lub Ø9mm

a)



b)



Item	Inlet thread	Order No.
a) Oxygen pressure regulator	M10x1	055.000.01
a) Oxygen pressure regulator	M12x1	055.000.00
b) Propane adapter	7/16"	962.500.00

MICRO-series nipples | Złączki serii MICRO



Used for disconnecting adaptors from hose Ø3.2mm to hose Ø6mm or Ø9mm



Służą do podłączania adapterów z węży Ø3.2mm do węży Ø6mm lub Ø9mm

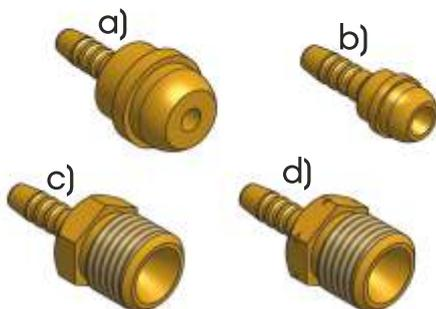

Description	Order No.
a) Nipple Ø3.2 for nut G3/8	947.000.00
b) Nipple Ø3.2 for nut G1/4	132.004.00
c) Nipple Ø3,2 – connection unit G1/4	947.000.06
d) Nipple Ø3,2 – connection unit G1/4LH	947.000.07
c(1)) Nipple Ø3,2 – connection unit G3/8	947.000.08
d(1)) Nipple Ø3,2 – connection unit G3/8LH	947.000.09

Brazing torch | "DONMET" 206 Jeweller | Palnik

PROPANE / METHANE / ACETYLENE / HYDROGEN / MAPP + OXYGEN

FLAME TEMPERATURE 2200-3100°C



Designed for jewellery and dentoprosthetic works, various crafts, modelling, repairs, production of electronic components, etc. Can be used for precision works required during brazing with soft and coarse solders, micro brazing, welding, spot heating, melting, etc.

The torch operates on gas fuels – propane, methane, acetylene and MAPP mixed with oxygen, as well as on detonating gas (oxyhydrogen gas).

A wide range of tips (7+1 included in the delivery set) of various capacity with the following nozzle diameters: 0,15mm; 0,25mm; 0,35mm; 0,5mm; 0,7mm; 1,0mm; 1,2mm allows to work with materials of different structures and thickness – from 0,01 mm.

The torch body is made of brass and thus not vulnerable to alkali medium which is important when operating from gas generators. A special valve design allows to accurately adjust the flame in a wide range with the flame remaining stable no matter how the torch is being handled.

PROPANE / GAZ ZIEMNY / ACETYLEN / WODÓR / MAPP + TIEN

TEMPERATURA PŁOMIENIU 2200-3100°C



Zaprojektowany do prac jubilerskich i protetycznych, różnych rzemiosł, modelowania, napraw, produkcji elementów elektronicznych itp.

Może być stosowany do precyzyjnych prac wymaganych podczas lutowania miękkiego i grubego lutu, lutowania twardego, spawania, ogrzewania punktowego, topienia itp.

Pochodnia działa na paliwach gazowych - propanie, metanie, acetylenie i MAPP zmieszanych z tlenem, a także na gazie detonującym (gazowy wodór).

Szeroka gama końcówek (7 + 1 w zestawie) o różnej zdolności z następującymi średnicami dysz: 0,15 mm; 0,25 mm; 0,35 mm; 0,5 mm; 0,7 mm; 1,0 mm; 1,2 mm pozwala na pracę z materiałami o różnych strukturach i grubościach – od 0,01 mm.

Korpus palnika jest wykonany z miedzi i dlatego nie jest wrażliwy na działanie alkaliów, co jest ważne podczas pracy z generatorów gazu. Specjalna konstrukcja zaworu pozwala dokładnie regulować płomień w szerokim zakresie, przy czym płomień pozostaje stabilny bez względu na sposób obsługi palnika.

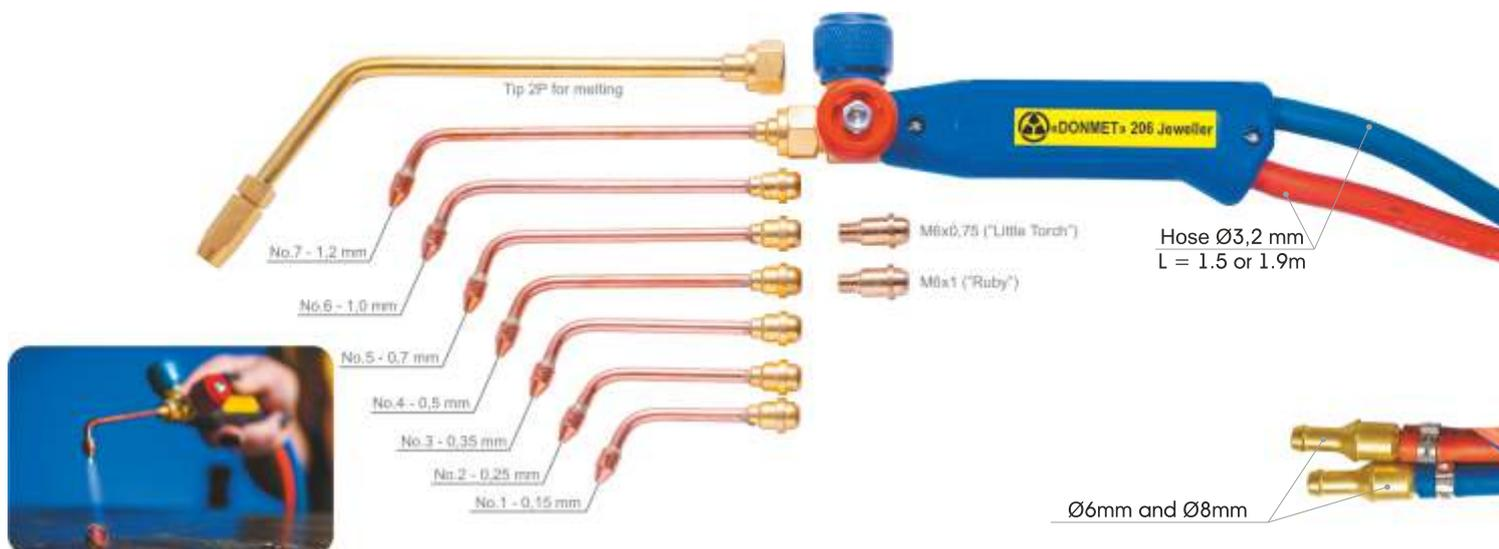

TECHNICAL SPECIFICATIONS

Pressure, bar	- oxygen	0,05...0,3
	- gas fuel (acetylene, hydrogen, propane-butane, etc.)	0,05...0,3
Consumption, l/h	- oxygen	70...200
	- gas fuel (acetylene, hydrogen, propane-butane, etc.)	70...200
Flame temperature (methane, propane, MAPP, acetylene) °C		2200...3100
Torch length with tip No.2, no more than, mm		200
Torch weight (with hoses L=1,9m), no more than, kg		0,55
Torch weight with tip No.2, no more than, kg		0,2

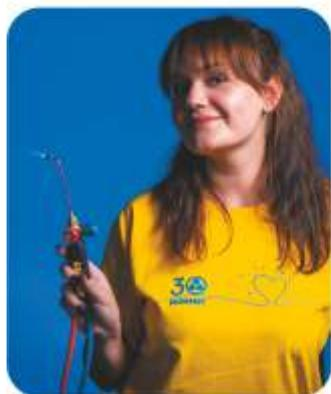

Item	Order No.
Torch "DONMET" 206-01 with a 1.5m hose (tips No.2, No.3, No.4, No.6)	206.000.01
Torch "DONMET" 206-02 with a 1.9m hose (tips No.1, No.2, No.3, No.4, No.5, No.6, No.7, No.2P adapters)	206.000.02



- small-size, portable and light-weight set for brazing, heating or cutting ferrous and non-ferrous metals in the field
- two tips included in the delivery set: for brazing and for cutting of metal
- flame temperature – 2400°C
- operating time while brazing:
 - oxygen cylinder – up to 1,5 hours
 - propane cylinder – up to 8 hours
- hoses length (Ø3,2 mm) – 1,5 m
- optimal size and weight, which makes it convenient for transportation and storage. The equipment can easily be brought into any building and to any floor without much effort.
- disposable oxygen cylinder – 1l (110-165bar) and disposable propane cylinder – 600ml (330g) are not included in the scope of delivery.



- Kompaktowy, mobilny i lekki zestaw montażowy do lutowania, ogrzewania lub cięcia metali żelaznych i nieżelaznych
- zestaw ma 2 końcówki: do lutowania i cięcia metali
- Temperatura płomienia – 2400°C
- czas pracy w trybie lutowania:
 - butla tlenowa – do 1,5 godziny
 - butla propanowa – do 8 godzin
- długość węży f3.2 mm - 1.5 m
- zestaw ma optymalne wymiary i wagę, co jest bardzo wygodne w transporcie i przechowywaniu. Sprzęt można łatwo wprowadzić do dowolnego budynku i na dowolnym poziomie bez większego wysiłku.
- zestaw nie zawiera: jednorazowej butli tlenowej - 1L (110-165 bar) i propanowej - 600 ml (330 g)



Item	Order No.
"DONMET" 994 MICRO Thread at the oxygen cylinder connection unit M10x1 (Kemper)	994.000.01
"DONMET" 994 MICRO Thread at the oxygen cylinder connection unit M12x1 (Oxyturbo, Providus, Castolin)	994.000.00



Cutting torch | "DONMET" 142 | Palnik do cięcia

SOTKA®
(Trademark)

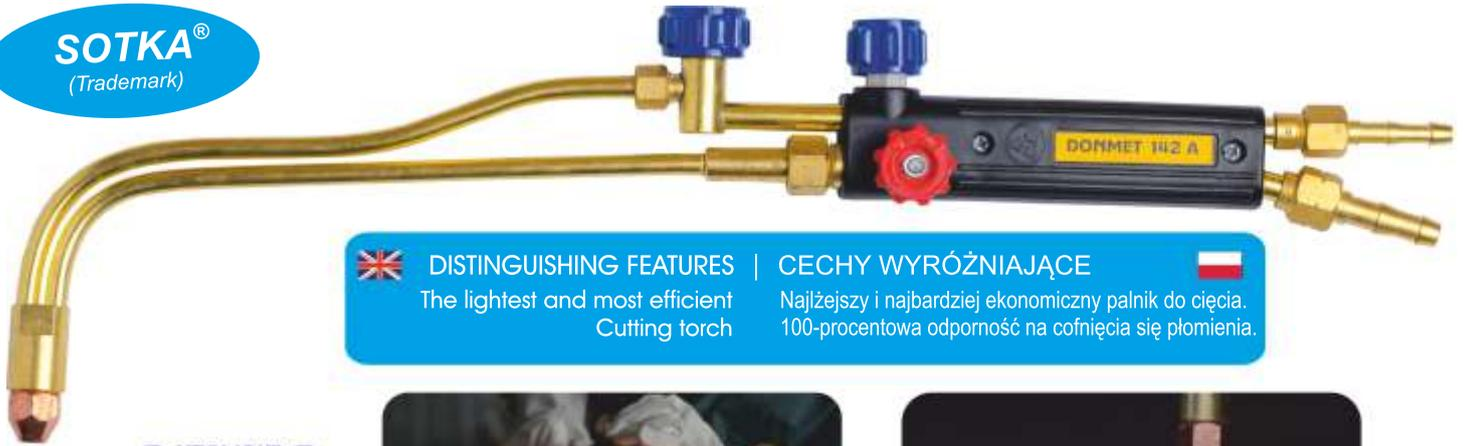

DISTINGUISHING FEATURES

The lightest and most efficient Cutting torch

CECHY WYRÓŻNIAJĄCE

Najlżejszy i najbardziej ekonomiczny palnik do cięcia. 100-procentowa odporność na cofnięcie się płomienia.

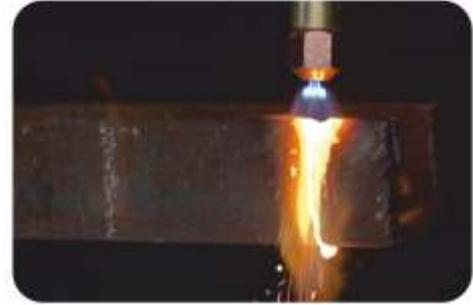

Cutting thickness	up to 100 mm
Zakres cięcia:	
Used gas fuel:	Acetylene (A)
Rodzaj gazu:	Propane-butane (P)
Cutting torch weight	0.75 kg
Waga:	
Cutting torch length	500 mm
Długość palnika:	

Item	Hose	Order No.
"DONMET" 142 A with groove nozzles dysza tnąca rowkowa	6/8	142.000.38
"DONMET" 142 P with groove nozzles dysza tnąca rowkowa	6/8	142.000.39
"DONMET" 142 P with ring nozzles dysza tnąca pierścieniowa	6/8	142.000.09

Cutting torch | "DONMET" 149 | Palnik do cięcia



DISTINGUISHING FEATURES

For work in hard-to-reach places!

CECHY WYRÓŻNIAJĄCE

Praca w przestrzeniach zamkniętych!



Cutting thickness	up to 100 mm
Zakres cięcia:	
Used gas fuel:	Propane-butane (P)
Rodzaj gazu:	
Cutting torch weight	0.75 kg
Waga:	
Cutting torch length	515 mm
Długość palnika:	

Item	Hose	Order No.
"DONMET" 149 P with ring nozzles dysza tnąca pierścieniowa	6/8	149.000.16

Cutting torch | "DONMET" 150 | Palnik do cięcia



	DISTINGUISHING FEATURES 100% safety; easy to operate with one hand in hard-to-reach places; light weight – 0.72 kg; oxygen economy up to 18%!		CECHY WYRÓŻNIAJĄCE 100% bezpieczeństwo; Praca jedną ręką w trudno dostępnych miejscach; łatwy – 0,72 kg; oszczędność do 18% tlenu.
--	---	--	---



	Cutting thickness	up to 100 mm
	Zakres cięcia:	up to 100 mm
	Used gas fuel:	Acetylene (A)
	Rodzaj gazu:	Propane-butane (P)
	Cutting torch weight	0.72 kg
	Waga:	0.72 kg
	Cutting torch length	500 mm
	Długość palnika:	500 mm

Item	Hose	Order No.
"DONMET" 150 A with groove nozzles dysza tnąca rowkowa	6/8	150.000.42
"DONMET" 150 P with groove nozzles dysza tnąca rowkowa	6/8	150.000.43
"DONMET" 150 P with ring nozzles dysza tnąca pierścieniowa	6/8	150.000.23

Cutting torch | "DONMET" 300 | Palnik do cięcia

TREKHSOTKA®
(Trademark)



	DISTINGUISHING FEATURES Light and high-power cutting torch		CECHY WYRÓŻNIAJĄCE Lekki i silny palnik do cięcia
--	--	--	---



	Cutting thickness	up to 300 mm
	Zakres cięcia:	up to 300 mm
	Used gas fuel:	Acetylene (A)
	Rodzaj gazu:	Propane-butane (P)
	Cutting torch weight	0.8 kg
	Waga:	0.8 kg
	Cutting torch length	520 mm
	Długość palnika:	520 mm

Item	Hose	Order No.
"DONMET" 300 A with groove nozzles dysza tnąca rowkowa	6/8	300.000.23
"DONMET" 300 P with groove nozzles dysza tnąca rowkowa	6/8	300.000.24
"DONMET" 300 P with ring nozzles dysza tnąca pierścieniowa	6/8	300.000.03



DISTINGUISHING FEATURES | **CECHY WYRÓŻNIAJĄCE**
 Cutting torch for professionals! | Palnik dla fachowców!



	Cutting thickness	up to 300 mm
	Zakres cięcia:	do 300 mm
	Used gas fuel:	Acetylene (A)
	Rodzaj gazu:	Propane-butane (P)
	Cutting torch weight	0.9 kg
	Waga:	0.9 kg
	Cutting torch length	507 mm
	Długość palnika:	507 mm

Item	Hose	Order No.
"DONMET" 337 A with groove nozzles dysza tnąca rowkowa	6/8	337.000.03
"DONMET" 337 P with groove nozzles dysza tnąca rowkowa	6/8	337.000.04
"DONMET" 337 P with ring nozzles dysza tnąca pierścieniowa	6/8	337.000.34

Torch cutting guide | Cyrkiel do stosowania z palnikami

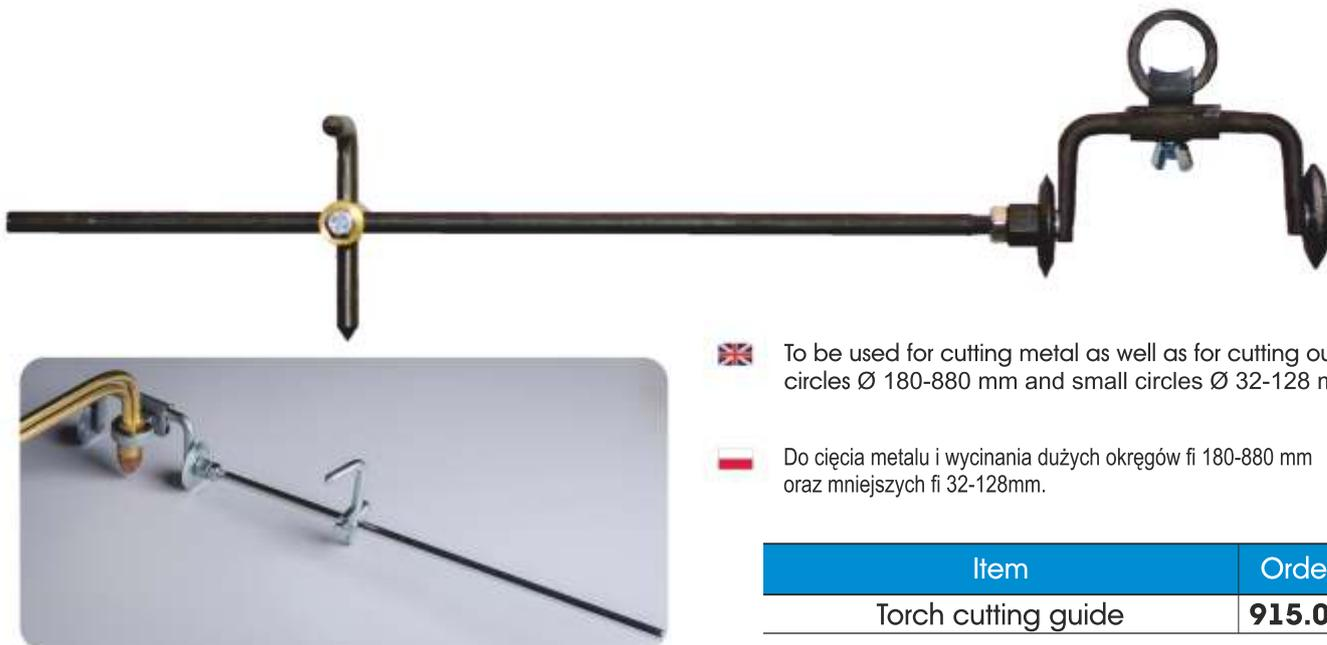

To be used for cutting metal as well as for cutting out big circles \varnothing 180-880 mm and small circles \varnothing 32-128 mm

Do cięcia metalu i wycinania dużych okręgów \varnothing 180-880 mm oraz mniejszych \varnothing 32-128mm.

Item	Order No.
Torch cutting guide	915.000.02

- universal cutting torch (quick transition to another type of gas: A, P, M)
- nozzle types (PNME/ANME/G1-A/G1-P)
- stylish design
- stamped brass body and head
- special stainless steel tube
- absolutely safe (the tubes do not burn through)
- light-weight, solid and durable design
- convenient and ergonomic – easy to handle in all spatial positions
- head bending angle 95°, 120° or 180°.

- uniwersalny palnik do cięcia (szybkie przejście do innego rodzaju gazu: A, P, M)
- współpracuje z dyszami blokowymi PNME/ANME/G1-A/G1-P
- Stylowy wygląd
- szlancowany korpus i głowica z mosiądzu
- rurki z stali nierdzewnej
- absolutnie bezpieczne (rurki się nie wypalają)
- lekka i trwała konstrukcja
- kąt nachylenia głowicy 95, 120 lub 180 dla wersji z "zaworem" i "dźwignią"

	Cutting thickness	up to 300 mm
	Zakres cięcia:	up to 300 mm
	Used gas fuel:	Acetylene (A)
	Rodzaj gazu:	Propane-butane (P)
		Methane (M) gaz ziemny

Cutting torch | "DONMET" 374 (lever) | Palnik do cięcia



Item	Nozzle type	Weight, kg	Length, mm	Head angle	Inlet thread (Hose)	Order No.
"DONMET" 374 (lever)	PNM PNME ANM ANME IC	0.9	551	95°	G1/4 (6) - G3/8LH (8)	374.000.12
"DONMET" 374 (lever)		0.9	557	120°		374.000.11
"DONMET" 374 (lever)		1.1	885	95°		374.000.16
"DONMET" 374 (lever)		1.1	897	120°		374.000.18
"DONMET" 374 (lever)		1.3	1200	120°		374.000.29
"DONMET" 374 (lever)		0.9	542	95°	G3/8 (8) - G3/8LH (8)	374.000.20
"DONMET" 374 (lever)		0.9	542	105°		374.000.22
"DONMET" 374 (lever)		1.1	882	105°		374.000.23
"DONMET" 374 (lever)		1.1	882	95°		374.000.21
"DONMET" 374 (lever)		1.5	1417	120°	G1/4 (6) - G3/8LH (8)	374.000.37
"DONMET" 374 (lever)		1.5	1443	180°		374.000.38
"DONMET" 374 (lever)		0.9	542	95°	M16x1,5 (9) - M16x1,5LH (9)	374.000.10
"DONMET" 374 (lever)		0.9	548	120°		374.000.15
"DONMET" 374 (lever)		0.9	574	180°		374.000.14
"DONMET" 374 (lever)		1.1	882	95°		374.000.13
"DONMET" 374 (lever)		1.1	888	120°		374.000.17
"DONMET" 374 (lever)		1.3	1200	120°		374.000.28
"DONMET" 374 (lever)		0.9	551	95°		G1/4 (6) - G3/8LH (8)
"DONMET" 374 (lever)		0.9	557	120°	374.000.26	
"DONMET" 374 (lever)		1.1	891	95°	374.000.25	
"DONMET" 374 (lever)	1.1	897	120°	374.000.27		
"DONMET" 374 (lever)	HP1	0.9	542	95°	M16x1,5 (9) - M16x1,5LH (9)	374.000.31
"DONMET" 374 (lever)	DH1	1.1	892	95°		374.000.32
"DONMET" 374 (lever)		1.1	892	120°		374.000.33
"DONMET" 374 (lever)		1.3	1200	120°		374.000.34

SERIES OF THREE-PIPE CUTTING TORCHES 374/362

with in-nozzle gas mixing: PNME, ANME, G1A, G1P



Cutting torch | "DONMET" 362 (valve) | Palnik do cięcia



Item	Nozzle type	Weight, kg	Length, mm	Head angle	Inlet thread (Hose)	Order No.
"DONMET" 362 (valve)	PNM PNME ANM ANME IC	0.9	551	95°	G1/4 (6)	362.000.51
"DONMET" 362 (valve)		0.9	557	120°		-
"DONMET" 362 (valve)		1.1	885	95°	G3/8LH (8)	362.000.53
"DONMET" 362 (valve)		1.1	897	120°		-
"DONMET" 362 (valve)		0.9	542	95°	G3/8 (8)	362.000.59
"DONMET" 362 (valve)		0.9	548	105°		-
"DONMET" 362 (valve)		1.1	888	105°	G3/8 (8)	362.000.62
"DONMET" 362 (valve)		1.1	882	95°		-
"DONMET" 362 (valve)		0.9	574	180°	G3/8LH (8)	362.000.67
"DONMET" 362 (valve)		0.9	548	120°		-
"DONMET" 362 (valve)		0.9	542	95°	M16x1,5 (9)	362.000.50
"DONMET" 362 (valve)		0.9	548	120°		-
"DONMET" 362 (valve)		0.9	574	180°	M16x1,5LH (9)	362.000.54
"DONMET" 362 (valve)		0.9	882	95°		-
"DONMET" 362 (valve)		0.9	888	120°	-	362.000.57
"DONMET" 362 (valve)		G1 A G1 P HP1 DH1	0.9	551	95°	G1/4 (6)
"DONMET" 362 (valve)	1.1		885	95°	-	
"DONMET" 362 (valve)	0.9		557	120°	G3/8LH (8)	362.000.65
"DONMET" 362 (valve)	1.1		897	120°		-
"DONMET" 362 (valve)	0.9		542	95°	M16x1,5 (9) - M16x1,5LH (9)	362.000.70

Torch cutting guide | Cyrkiel do stosowania z palnikami

Designed to ensure the stability of cutting straight and curved trajectories when cutting metal with a manual cutting torch "DONMET" 374 with nozzles type PNME/ANME/G1

- ▶ cutting along a straight line and removing chamfers using a universal head and a drill
- ▶ cutting along a small and large radius (from 15 up to 410 mm)
- ▶ suitable for cutting torches with an S24 union nut

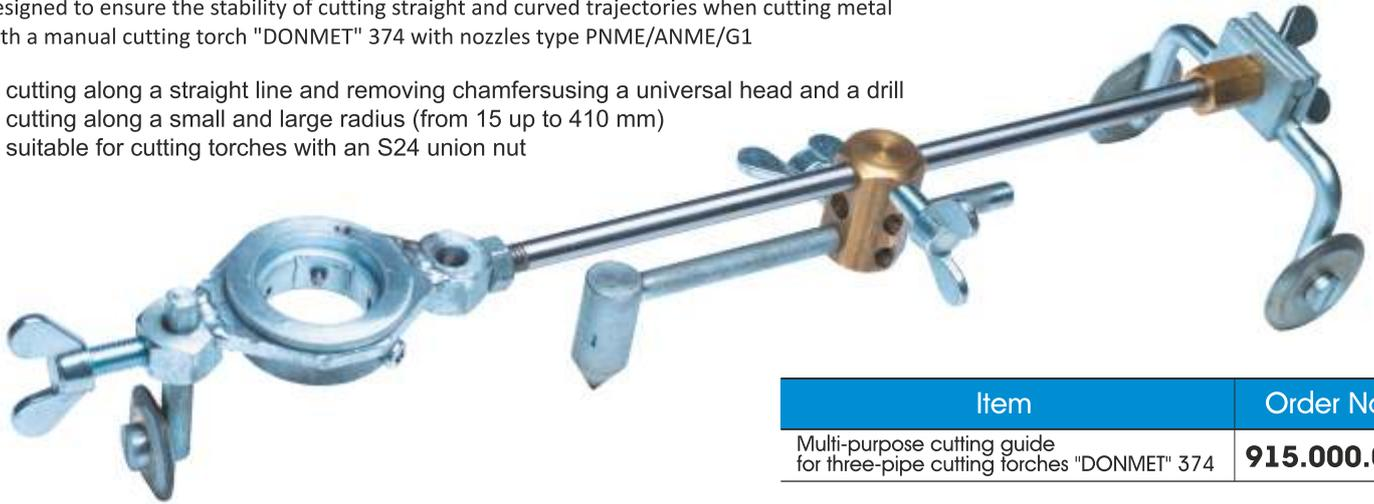

Item	Order No.
Multi-purpose cutting guide for three-pipe cutting torches "DONMET" 374	915.000.00

Nozzles type PNME/ANME | Dysze blokowe PNME/ANME



Propane/methane gas-mixing nozzles with slotted grooves

Dysza blokowa propanowa rowkowa

No.0PM	3-8 mm	344.600.00
No.1PM	8-15 mm	344.600.01
No.2PM	15-30 mm	344.600.02
No.3PM	30-50 mm	344.600.03
No.4PM	50-100 mm	344.600.04
No.5PM	100-200 mm	344.600.05
No.6PM	200-300 mm	344.600.06



Propane/methane gas-mixing nozzles with slotted grooves

Dysza blokowa propanowa rowkowa

No.0PM (PNME 1/32)	3-10 mm	374.700.00
No.1PM (PNME 3/64)	8-15 mm	374.700.01
No.2PM (PNME 1/16)	15-30 mm	374.700.02
No.3PM (PNME 5/64)	30-50 mm	374.700.03
No.4PM (PNME 3/32)	50-100 mm	374.700.04
No.5PM (PNME 7/64)	100-200 mm	374.700.05
No.6PM (PNME 1/8)	200-300 mm	374.700.06



Acetylene gas-mixing nozzle

Dysza blokowa acetylenowa

No.0A (ANME 1/32)	3-10 mm	374.600.00
No.1A (ANME 3/64)	8-15 mm	374.600.01
No.2A (ANME 1/16)	15-30 mm	374.600.02
No.3A (ANME 5/64)	30-50 mm	374.600.03
No.4A (ANME 3/32)	50-100 mm	374.600.04
No.5A (ANME 7/64)	100-200 mm	374.600.05
No.6A (ANME 1/8)	200-300 mm	374.600.06

Nozzles type G1 | Dysze blokowe G1



Propane/methane gas-mixing nozzles with slotted grooves

Dysza blokowa propanowa rowkowa

G1-P 7/10	3-10 mm	374.800.00
G1-P 10/10	10-25 mm	374.800.01
G1-P 12/10	25-50 mm	374.800.02
G1-P 16/10	50-80 mm	374.800.03
G1-P 20/10	80-120 mm	374.800.04
G1-P 25/10	120-200 mm	374.800.05
G1-P 30/10	200-300 mm	374.800.06



Acetylene gas-mixing nozzle

Dysza blokowa acetylenowa

G1-A 7/10	3-10 mm	374.900.00
G1-A 10/10	10-25 mm	374.900.01
G1-A 12/10	25-50 mm	374.900.02
G1-A 16/10	50-80 mm	374.900.03
G1-A 20/10	80-120 mm	374.900.04
G1-A 25/10	120-200 mm	374.900.05
G1-A 30/10	200-300 mm	374.900.06

Nozzles for finishing cutting type NX | Dysze do precyzyjnego cięcia typu NX



Size	Cutting thickness	Oxygen pressure	Order №
№000	0-5 mm	1-2 bar	360.005.00
№00	5-10 mm	1.5-2 bar	360.005.01
№0	10-15 mm	2-3 bar	360.005.02
№1	15-25 mm	2.5-3.5 bar	360.005.03
№2	25-50 mm	3-4 bar	360.005.04
№3	50-75 mm	3-4.5 bar	360.005.05
№4	75-150 mm	3.5-5.5 bar	360.005.06
№5	150-200 mm	4.5-5.5 bar	360.005.07
№6	200-300 mm	5-6.5 bar	360.005.08

Cutting torch | "DONMET" 360 | Palnik do cięcia



LOW-PRESSURE THREE-PIPE CUTTING TORCH DONMET 360

propane-butane, acetylene, methane

Injection-type three-pipe cutting torch of increased reliability for cutting metal up to 300mm thick.

- compatible with "6290"-type nozzles of many world manufacturers
- sturdy and rigid soldered design with stainless steel tubes
- intense and focused preheating flame – quicker cutting-in
- strengthened mixing chamber and injector are placed inside a massive head which ensures safe operation and the cutter's safety in case of flashbacks
- stop valves design ensures fine flame adjustment
- comfortable ergonomic handle and perfect cutting torch balance



PALNIK DO CIĘCIA INŻEKTOROWY DONMET 360

propan, acetylen, gaz ziemny

Palnik inżektorowy o wysokiej niezawodności do cięcia metali o grubości do 300mm.

- kompatybilny z dyszami wielu światowych producentów systemu "6290"
- trwała i sztywna lutowana konstrukcja z rurkami ze stali nierdzewnej
- mocny skoncentrowany płomień rozgrzewający - zwiększona prędkość cięcia
- wzmocniona komora mieszania i inżektor znajdują się w masywnej głowicy, co zapewnia bezpieczną pracę i bezpieczeństwo palnika podczas odwrotnych uderzeń
- konstrukcja zaworów zapewnia precyzyjne dostrojenie płomienia
- wygodny ergonomiczny uchwyt i doskonałe wyważenie palnika

EN ISO 5172

Cutting torch | "DONMET" 360 (lever) | Palnik do cięcia



Item	Nozzle type	Weight, kg	Length, mm	Head angle	Inlet thread (Hose)	Order No.	
"DONMET" 360 P	6290: NX, NFF, ND	0.98	520	95°	G1/4 (6)	360.000.00	
"DONMET" 360 P L		1.15	820	95°	-	360.000.01	
"DONMET" 360 P L-1200mm		1.4	1200	95°	G3/8LH (8)	360.000.02	
"DONMET" 360 P		0.98	520	95°	G3/8 (8)	360.000.10	
"DONMET" 360 P L		1.15	820	95°	-	360.000.11	
"DONMET" 360 P L-1200mm		1.4	1200	95°	G3/8LH (8)	360.000.12	
"DONMET" 360 P		0.98	520	95°	16x150 D (R) (6/10)	360.000.20	
"DONMET" 360 P L		1.15	820	95°		-	360.000.21
"DONMET" 360 P L-1200mm		1.4	1200	95°		16x150 G (L) (6/10)	360.000.22

Cutting torch | "DONMET" 361 (valve) | Palnik do cięcia

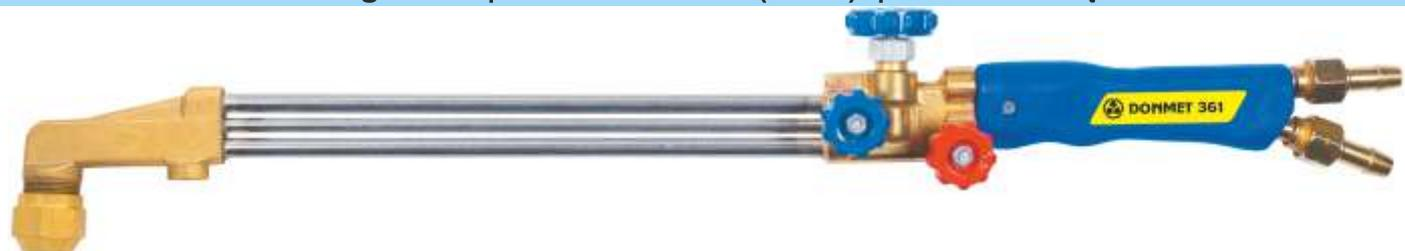

Item	Nozzle type	Weight, kg	Length, mm	Head angle	Inlet thread (Hose)	Order No.	
"DONMET" 361 P	6290: NX, NFF, ND	0.98	524	95°	G1/4 (6)	361.000.03	
"DONMET" 361 P L		1.15	804	95°	-	361.000.04	
"DONMET" 361 P L-1200mm		1.4	1224	95°	G3/8LH (8)	361.000.05	
"DONMET" 361 P		0.98	524	95°	G3/8 (8)	361.000.13	
"DONMET" 361 P L		1.15	804	95°	-	361.000.14	
"DONMET" 361 P L-1200mm		1.4	1224	95°	G3/8LH (8)	361.000.15	
"DONMET" 361 P		0.98	524	95°	16x150 D (R) (6/10)	361.000.23	
"DONMET" 361 P L		1.15	804	95°		-	361.000.24
"DONMET" 361 P L-1200mm		1.4	1224	95°		16x150 G (L) (6/10)	361.000.25

Cutting torch | "DONMET" 142U | Palnik do cięcia



	Cutting thickness	up to 100 mm
	Zakres cięcia:	up to 100 mm
	Used gas fuel:	Propane-butane (P)
	Rodzaj gazu:	Propane-butane (P)
	Cutting torch weight	0.85 kg
	Waga:	0.85 kg
	Cutting torch length	750 mm
	Długość palnika:	750 mm

Item	Hose	Order No.
"DONMET" 142U P with groove nozzles dysza tnąca rowkowa	6/8	142.000.34
"DONMET" 142U P with ring nozzles dysza tnąca pierścieniowa	6/8	142.000.05

Cutting torch | "DONMET" 300U | Palnik do cięcia



	Cutting thickness	up to 300 mm
	Zakres cięcia:	up to 300 mm
	Used gas fuel:	Propane-butane (P)
	Rodzaj gazu:	Propane-butane (P)
	Cutting torch weight	1.15 kg
	Waga:	1.15 kg
	Cutting torch length	960 mm
	Długość palnika:	960 mm

Item	Hose	Order No.
"DONMET" 300U P with groove nozzles dysza tnąca rowkowa	6/8	300.000.28
"DONMET" 300U P with ring nozzles dysza tnąca pierścieniowa	6/8	300.000.08

Cutting torch | "DONMET" 337U | Palnik do cięcia

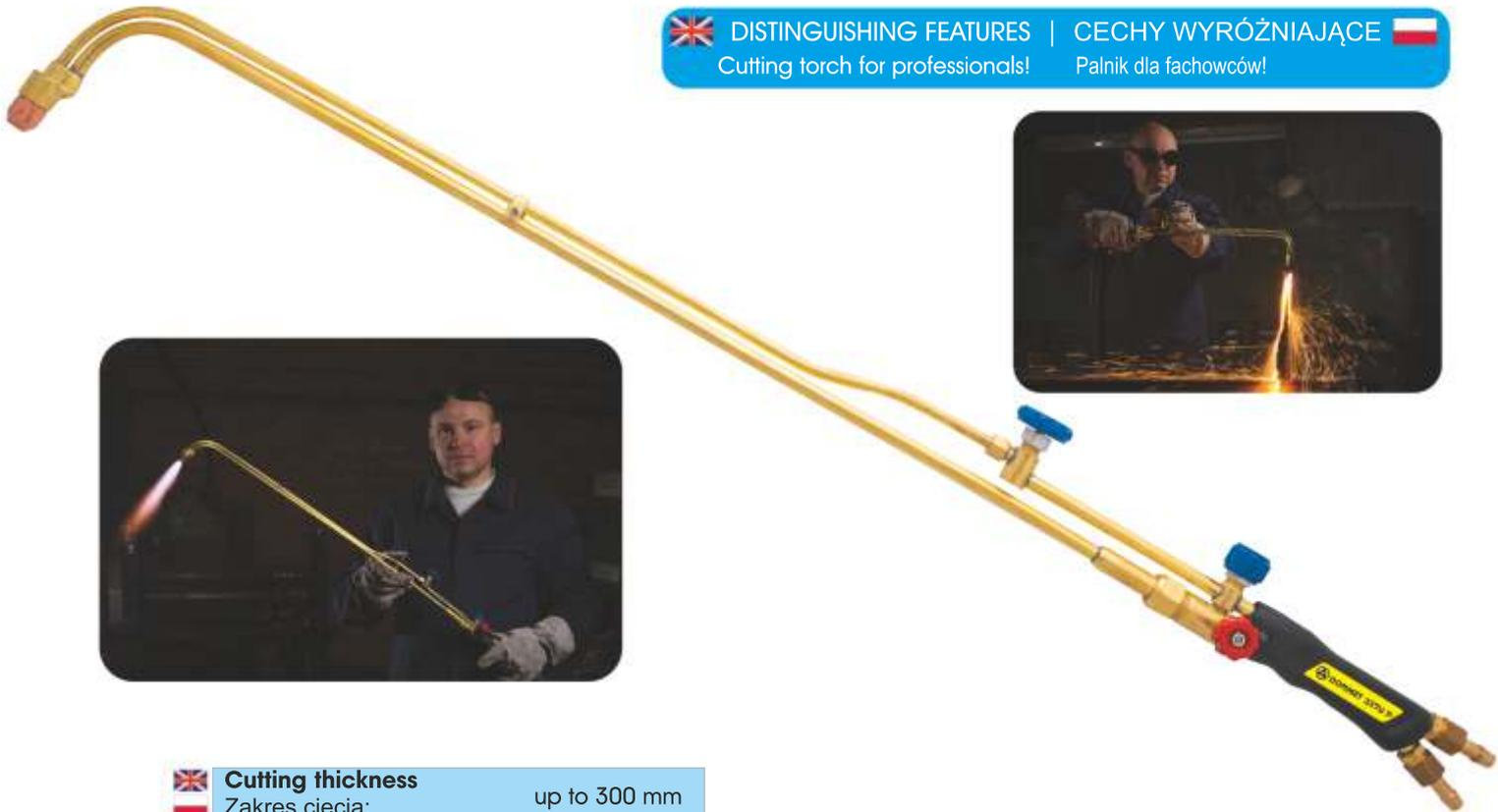

DISTINGUISHING FEATURES | **CECHY WYRÓŻNIAJĄCE**
Cutting torch for professionals! | Palnik dla fachowców!



	Cutting thickness	up to 300 mm
	Zakres cięcia:	up to 300 mm
	Used gas fuel:	Propane-butane (P)
	Rodzaj gazu:	Methane (M) gaz ziemny
	Cutting torch weight	1.22 kg
	Waga:	1.22 kg
	Cutting torch length	1000 mm
	Długość palnika:	1000 mm

Item	Hose	Order No.
"DONMET" 337U P with groove nozzles dysza tnąca rowkowa	6/8	337.000.27
"DONMET" 337U P with ring nozzles dysza tnąca pierścieniowa	6/8	337.000.07
"DONMET" 337U M with ring nozzles dysza tnąca pierścieniowa	6/8	337.000.08

Cutting torch | "DONMET" 502 | Palnik do cięcia



DISTINGUISHING FEATURES | **CECHY WYRÓŻNIAJĄCE**
High-power
Professional cutting torch
For cutting and gouging
of metals up to 500 mm thick
Palnik o wysokiej mocy.
Znakomicie nadaje się do cięcia złomu
o grubości do 500mm.



	Cutting thickness	up to 500 mm
	Zakres cięcia:	up to 500 mm
	Used gas fuel:	Propane-butane (P)
	Rodzaj gazu:	Methane (M) gaz ziemny
	Cutting torch weight	1.97 kg
	Waga:	1.97 kg
	Cutting torch length	1300 mm
	Długość palnika:	1300 mm

Item	Hose	Order No.
"DONMET" 502 M	8/8	502.000.26
"DONMET" 502 P	8/8	502.000.25



OXY-DIESEL(GASOLINE) CUTTING TORCH «DONMET» 185 DG

is designed for oxy-diesel cutting up to 200mm of low-carbon and low-alloy steels in the presence of an oxygen source (oxygen line, manifold or cylinders) using diesel fuel.

Torches are used for cutting with liquid fuels and oxygen.

The choice of Diesel Technology for metal cutting works is preferable because diesel torches is safer than gasoline torches and about 70% more economical than acetylene. Moreover, when cutting metal with thickness more than 50mm, the cutting speed is 25-30% higher than when using propane or acetylene as a fuel gas. Diesel cutting technology provides nearly 100% of oxidation, complete vaporization and combustion of diesel fuel during cutting, so little slag is left behind, and the cut is cleaner. Thanks to that, the Diesel cutting torch can be successfully used for Multi-layer cutting.

To operate Diesel cutting torch DONMET you need standard compressed oxygen with Diesel as a fuel (instead of acetylene or propane). Ordinary diesel fuel is used as the fuel for Diesel Cutting Torches «DONMET» 185. You can buy it at every gas station.

The combustion of diesel fuel in oxygen gives a high-speed density flame, which cuts dirty and rusty metal, metal or reinforced concrete with voids, multiple stacked layers in a highly efficient manner.

Due to the unique design of the diesel cutting torch, the cutting flame is stable and does not change shape when tilted at any angle or spatial position, even when shaking the torch vigorously, the shape of the flame will not change.

The durable, reliable and long-life construction of the diesel torch DONMET 185 is ensured by the use of stainless steel and brass components.

The usual positioning of control valves allows you to set up and operate the diesel cutting torch DONMET like a traditional gas torch.

The special design of the preheating nozzle and mixing device provides 100% resistance to flashback. And for complete safety an oxygen flashback arrestor is installed at the inlet torch connection. In addition, diesel fuel is absolutely safe and stable in storage and operation: it cannot ignite or explode unless it is sprayed or vaporized.

The use of diesel fuel allows the cutting torch to be used at low temperatures from -40°C in the ambient air, while propane does not vaporize.



PALNIK DO CIĘCIA TLEN-DIESEL (benzyna) «DONMET» 185 DG

PALNIK DO CIĘCIA TLEN-DIESEL (benzyna) «DONMET» 185 DG przeznaczony jest do cięcia tlenowo-dieslowego do 200 mm stali niskowęglowych i niskostopowych w obecności źródła tlenu (przewód tlenowy, kolektor lub cylindry) przy użyciu oleju napędowego.

Do cięcia paliwami ciekłymi i tlenem służą palniki naftowe lub palniki na olej napędowy.

Wybór technologii Diesla do prac związanych z cięciem metalu jest preferowany, ponieważ palniki na olej napędowy są bezpieczniejsze niż palniki na benzynę (palniki benzynowe) i około 70% bardziej ekonomiczne niż acetylen. Ponadto przy cięciu metalu o grubości większej niż 50 mm prędkość cięcia jest o 25-30% większa niż w przypadku stosowania propanu lub acetyleny jako paliwa gazowego. Technologia cięcia olejem napędowym zapewnia prawie 100% utleniania, całkowitego odparowania i spalania oleju napędowego podczas cięcia, dzięki czemu pozostaje niewielka ilość żużla, a cięcie jest czystsze. Dzięki temu palnik Diesel może być z powodzeniem stosowany do cięcia wielowarstwowego.

Do obsługi palnika do cięcia Dieselem DONMET potrzebny jest standardowy sprężony tlen z olejem napędowym jako paliwem (zamiast acetyleny lub propanu). Jako paliwo do palników tnących «DONMET» 185 stosuje się zwykły olej napędowy. Można go kupić na każdej stacji benzynowej.

Spalanie oleju napędowego w tlenie daje płomień o dużej prędkości i gęstości, który w bardzo wydajny sposób tnie brudny i zardzewiały metal, metal lub żelbet z pustymi przestrzeniami, wiele warstw.

Dzięki unikalnej konstrukcji palnika do cięcia Diesel, płomień cięcia jest stabilny i nie zmienia kształtu pod dowolnym kątem i w dowolnej pozycji przestrzennej, nawet przy energicznym potrząsaniu palnikiem kształt płomienia nie ulegnie zmianie.

Trwała, niezawodną i długoletnią konstrukcją palnika dieslowego DONMET 185 zapewnia zastosowanie elementów ze stali nierdzewnej i mosiądzu.

Typowe rozmieszczenie zaworów sterujących pozwala na ustawienie i obsługę palnika dieslowego DONMET jak tradycyjnego palnika gazowego.

Specjalna konstrukcja dyszy podgrzewającej i urządzenia mieszającego zapewnia 100% odporność na cofanie się płomienia. Dla całkowitego bezpieczeństwa na złączu wlotowym palnika zainstalowano zabezpieczenie przed gazem zwrotnym tlenu. Ponadto olej napędowy jest całkowicie bezpieczny i stabilny podczas przechowywania i eksploatacji: nie może się zapalić ani eksplodować, chyba że zostanie rozpylony lub odparowany.

Zastosowanie oleju napędowego pozwala na pracę palnika do cięcia w niskich temperaturach powietrza otoczenia już od -40°C, przy czym propan nie paruje.



Cutting thickness	3 - 200 mm
Zakres cięcia:	
Used gas fuel:	Diesel
Rodzaj gazu:	
Oxygen inlet thread (hose)	9/16-18UNF
Gwint wlotu tlenu (wąż):	
Gas fuel inlet thread (hose)	9/16-18LH UNF
Gwint wlotu gazowego (wąż):	
Cutting torch weight	1.1 / 1.4 / 1.45 kg
Waga:	
Cutting torch length	630 / 1170 / 1220 mm
Długość palnika:	

Item	Length, mm	Head angle	Order No.
“DONMET” 185 DG	630	90°	185.000.00
“DONMET” 185 DG	1170	90°	185.000.10
“DONMET” 185 DG	1220	180°	185.000.20

TANK | DG-08-1 DM | Zbiornik diesel-benzyny



The Tank DG-08-1 DM, hereinafter referred to as the "tank", is designed to supply diesel fuel, gasoline and kerosene under pressure to cutting torches and heating torches.

The tank is manufactured in accordance with the requirements of the available design documentation DG 24.009-935.00.000-01 and in accordance with the requirements of Directive 2014/29/EU.

Zbiornik DG-08-1 DM jest przeznaczony do dostarczania oleju napędowego, benzyny i nafty pod ciśnieniem do palników do cięcia i palników grzewczych.

Zbiornik został wyprodukowany zgodnie z wymaganiami dyrektywy 2014/29/UE.



	Tank capacity	8±0.2 l
	Pojemność zbiornika:	8±0.2 l
	Fuel volume, not more than	6 l
	Objętość paliwa, nie więcej niż:	6 l
	Operating pressure	0.5-3 bar
	Ciśnienie robocze:	0.5-3 bar
	Diesel consumption	0.85-1.7 kg/h
	Diesel zużycie:	0.85-1.7 kg/h
	Connection unit thread	9/16-18LH UNF
	Gwint jednostki przyłączeniowej:	9/16-18LH UNF
	Hose inner diametr	6 mm
	Średnica wewnętrzna węża:	6 mm
	Weight	4.5 kg
	Waga:	4.5 kg

Item	Order No.
TANK DG-08-1 DM	935.000.01

OXY-FUEL CUTTING KIT No.3 | ZESTAW DO CIĘCIA TLENO-PALIWOWEGO nr 3

The **OXY-FUEL CUTTING KIT No.3** is designed for oxy-fuel cutting up to 200mm of low-carbon and low-alloy steels in the presence of an oxygen source (oxygen line, manifold or cylinders) using diesel fuel. Petrogen torches or diesel torches are used for cutting with liquid fuels and oxygen.

Delivery set of the Diesel Cutting Kit DONMET 971

Tank DG-08-1 DM935.000.01	1
Oxy-diesel cutting torch "DONMET" 185 DG (L=630mm)185.000.00	1
Cylinder pressure regulator RO-200-2 DM 044.000.16	1
Multi-purpose wrench909.001.01	1
Oxygen hose ø6mm L=8m, Dn=6 mm	1
Diesel resistant hose ø6mm L=6m, Dn=6 mm	1
Preheating nozzle No.1D181.500.02	1
Cutting nozzle No.2D181.001.24	1
Cutting nozzle No.5D181.001.27	1
Hose clamp	4
Pressure gauge 0,6 MPa005.051.00	1

ZESTAW DO CIĘCIA TLENO-PALIWOWEGO nr 3 jest przeznaczony do cięcia tlenowo-dieslowego do 200 mm stali niskowęglowych i niskostopowych w obecności źródła tlenu (linii tlenowej, kolektora lub butli) przy użyciu oleju napędowego. Palniki benzynowe lub wysokopiężne są używane do cięcia przy użyciu paliw płynnych i tlenu.

SKŁAD KOMPLETU «Diesel Cutting Kit DONMET 971»

Zbiornik DG-08-1 DM935.000.011	1
PALNIK DO CIĘCIA TLEN-DIESEL (benzyna) «DONMET» 185 DG (L=630mm) 185.000.001	1
Regulator ciśnienia tlenu RO-200-2 DM 044.000.161	1
Klucz uniwersalny909.001.011	1
Wąż tlenowy ø6mm L=8m, Dn=6 mm1	1
Wąż do diesel ø6mm L=6m, Dn=6 mm1	1
Dysza podgrzewająca No.1D1	1
Dysza tnąca No.2D181.001.241	1
Dysza tnąca No.5D181.001.271	1
Zacisk węża4	4
Manometr 0,6 MPa005.051.001	1



Item	Order No.
OXY-FUEL CUTTING KIT No.3	971.000.04

Machine cutting torches | "DONMET" 345 | Maszynowy palnik

for gas-cutting machines made in Poland, Czech Republic, Italy, produced by "Messer Greisheim" Germany; "SAF" France; "ASHNM" USA; "WESCOL" Great Britain; "Tanaka" Japan. In-nozzle gas mixing.

Maszynowy palnik gazowo-tlenowy przeznaczony jest do cięcia stali o grubości 3 – 300 mm. W zależności od zastosowanej dyszy możliwe jest cięcie acetylenem lub propanem. Palnik współpracuje z dyszami blokowymi typu PNME oraz ANME.

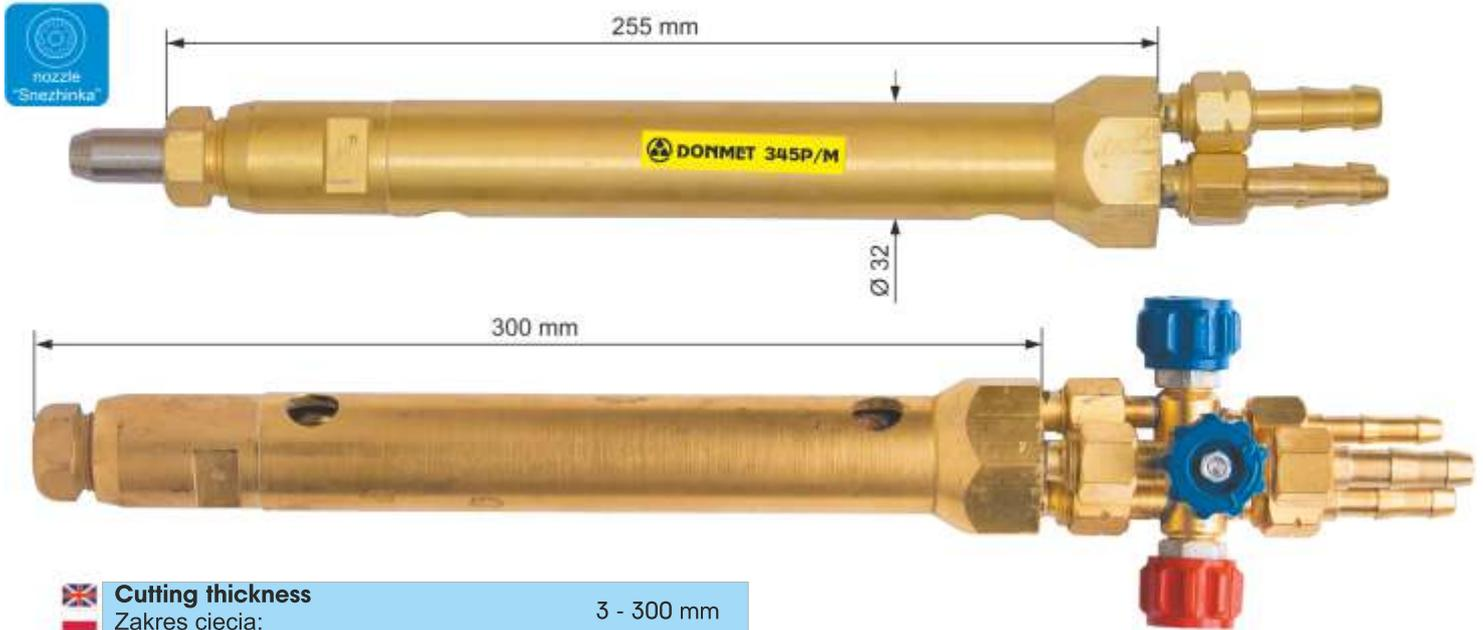

	Cutting thickness	3 - 300 mm
	Zakres cięcia:	3 - 300 mm
	Used gas fuel:	Propane-butane (P)
	Rodzaj gazu:	Methane (M) gaz ziemny
	Inlet connection thread diameter:	(8/6/8)
	Gwint nakrętki na wlocie:	
	cutting oxygen:	G3/8
	tlen do cięcia:	
	preheating oxygen:	G1/4
	tlen do podgrzewania:	
	gas fuel:	G3/8LH
	gaz palny:	
	Cutting torch head thread:	M22x1.5
	Gwint w głowicy:	
	Socket for nozzle:	30°
	Kąt dla dysz:	

Item	Length, mm	Order No.
"DONMET" 345	284	345.000.00
"DONMET" 345-16	343	345.000.16

Nozzle | "SNEZHINKA"® | Dysza mieszająca

Propane/methane gas mixing nozzle for machine cutting torches

Gas mixing nozzles "Snezhinka" are designed for machine cutting torches operating on methane or propane-butane.

The nozzles are compatible with balanced-pressure cutting torches made by: "DONMET", Ukraine; "MESSER GREISHEIM", Germany; "SAF", France; "ASHNM", USA; "WESCOL", Great Britain; some CIS companies, Poland, Czech Republic, Italy, "Tanaka" Japan.

Dysza mieszająca gazy (propan/metan) do palników maszynowych

Dysze mogą pracować z palnikami bez wtryskiwacza wyprodukowanymi przez producentów: "DONMET" Ukraina, MESSER, wiele firm z Polski, Czech, Włoch i Japonii.

- Użycie dyszy umożliwia:
- zmniejszenie zużycia tlenu i gazu palnego od 5 do 15% (w zależności od szerokości cięcia)
 - skrócenie czasu pogłębiania do metali do 20%
 - przyspieszenie cięcia do 30%
 - zmniejszenie szerokości cięcia

Your first step towards energy saving!!!



Marking	Cutting capacity, mm	Oxygen (pressure, kgf/cm ²)			Propane / methane (pressure, kgf/cm ²)	Cutting speed, mm/min	Order No.
		cutting	heating	Propane Methane			
OPM	3-10	3.0	2.0	2.0	0.2-0.5	640-550	345.300.20
1PM	10-15	4.0	2.0	2.0	0.2-0.5	550-480	345.300.21
2PM	15-25	5.0	2.0	2.0	0.2-0.5	480-400	345.300.22
3PM	25-50	6.0	2.0	2.0	0.2-0.5	400-320	345.300.23
4PM	50-100	6.0	2.0	2.0	0.2-0.5	320-230	345.300.24
5P	100-200	7.5	2.0	2.0	0.2-0.5	260-170	345.300.25
6P	200-300	8.5	2.0	2.0	0.2-0.5	180-100	345.300.26
5M	100-200	7.5	2.0	2.0	0.2-0.5	260-170	345.300.27
6M	200-300	8.5	2.0	2.0	0.2-0.5	180-100	345.300.28

Flux cutting set | KFR 954DM | Komplekt do cięcia proszkowego

for cutting cast-iron and stainless steel up to 200mm thick



Purposed for: manual parting cutting of stainless steel, grey iron and other materials that cannot be cut by ordinary oxy-fuel cutting methods.

The nature of oxy-flux cutting is that a jet of gas fuel continuously carries powdered flux based on small-granular iron powder (grain size 0,02...0,04mm) to the cutting area. While burning iron generates additional heat, lowers the concentration of alloying constituents in the reaction zone and thins the dross, thus facilitating its removal from the cutting zone.

Delivery set contains:

- flux batcher with an adjustable swirling-type mixer (flux tank of 20kg capacity) equipped with a safety device and a flashback arrester;
- cutting torch with in-nozzle gas mixing KFR-352-15/17 with an attachment for supplying flux;
- three gas-feeding rubber-fabric hoses (9mm);
- cart with an attachment;
- propane pressure regulator.

The basis of all fluxes for oxy-flux cutting is iron powder that in most cases is used just as it is, especially for cutting steel and grey iron.



Do cięcia żeliwa, stali nierdzewnej i innych stali wysokiej jakości w hutnictwie, odlewnictwie oraz na złomach.

Dane techniczne:

Zakres cięcia: 5 - 200 mm
 Wypełnienie proszkiem: max 22 kg
 Ciśnienie gazu palnego: 0,2 - 0,4 bar
 Ciśnienie tlenu: 5 - 8 bar
 Max zużycie tlenu tnącego – 24m³/h
 Gaz palny: propan, propan-butan, MPP

Item	Order No.
KFR 954-07	954.000.07

TECHNICAL SPECIFICATION

Cutting thickness, mm		3 - 200
Inlet pressure, kgf/cm ²	oxygen	2,5 - 8
	gas fuel, MPP, P	0,2-1,0
Maximum consumption, m ³ /h	oxygen for MPP / P	2,5-19 / 2,6-24
	MPP / P	0,48 - 1,1
	propane-butane	0,35 - 0,88
Cutting torch weight no more than, kg		1,48
Cutting torch length no more than, mm		900
Cutting torch head thread		M22x1,5
Head seating cone angle, degrees		30° + 3'



Welding torch | "MALYATKO" 233 | Palnik do spawania gazowego

ACETYLENE



	Welding capacity: Grubość spawanego metalu:	0.2 - 4 mm
	Used gas fuel: Gaz palny:	Acetylene (A)
	Scope of delivery: Kompletacja:	Gas-welding tips No. 0, 1, 2, 3
	Torch weight: Waga:	0.3 kg
	Torch length: Długość palnika:	390 mm (with No.3)



Item	Inlet connection (hose)	Country	Order No.
"DONMET" 233	G1/4 (6) - G3/8LH (8)	Poland, Bulgaria, Germany, Austria, Switzerland, Czech Republic, Slovakia, Hungary, Scandinavia, Romania	233.000.04
"DONMET" 233	G1/4 (6) - G1/4LH (6)	Italy	233.000.05
"DONMET" 233	M12x1 (6) /M12x1LH (6)	Greece, France	233.000.13
"DONMET" 233	M12x1,25 (6) /M12x1,25LH (6)	Ukraine, Lithuania, Latvia, Estonia	233.000.02

Welding torch | "MINI DM" 273 | Palnik do spawania gazowego

ACETYLENE



DISTINGUISHING FEATURES
IDEAL FOR HOUSING AND MUNICIPAL SERVICES WORK!
SEAMLESS COPPER TIP!

CECHY WYRÓZNIAJĄCE
Maksymalna niezawodność.
Pozwala na efektywną pracę w trudno dostępnych miejscach.
Minimalna dopuszczalna przestrzeń: 40 mm.
Możliwość długotrwałego użytkowania bez potrzeby chłodzenia dzięki bezzwowej miedzianej końcówce.
Długowieczność. Uchwyt z odpornego na uderzenia polistyrenu.
Idealne narzędzie do prac komunalnych.

	Welding capacity: Grubość spawanego metalu:	1 - 4 mm
	Used gas fuel: Gaz palny:	Acetylene (A)
	Scope of delivery: Kompletacja:	gas welding seamless copper tips No. 2,3 can be completed with tips: No. 0,1,4
	Torch weight: Waga:	0.29 kg
	Torch length: Długość palnika:	390 mm (with No. 3)



Item	Inlet connection (hose)	Country	Order No.
"MINI DM" 273	G1/4 (6) - G3/8LH (8)	Poland, Bulgaria, Germany, Austria, Switzerland, Slovakia, Czech Republic, Hungary, Sweden, Norway, Romania	273.000.08
"MINI DM" 273	G1/4 (6) - G1/4LH (6)	Italy	273.000.12
"MINI DM" 273	M12x1 (6) /M12x1LH (6)	Greece, France	273.000.13
"MINI DM" 273	M12x1,25 (6) /M12x1,25LH (6)	Ukraine, Lithuania, Latvia, Estonia	273.000.05

Welding torch | "DONMET" 225 | Palnik do spawania gazowego



ACETYLENE

	Welding capacity:	1 - 7 mm
	Grubość spawanego metalu:	1 - 7 mm
	Used gas fuel:	Acetylene (A)
	Gaz palny:	Acetylene (A)
	Scope of delivery:	gas welding tips No. 2, 3 or 3, 4
	Kompletacja:	gas welding tips No. 2, 3 or 3, 4
	Torch weight:	0.41 kg
	Waga:	0.41 kg
	Torch length:	400 mm (with No.3)
	Długość palnika:	400 mm (with No.3)

Item	Inlet connection (hose)	Country	Order No.
"DONMET" 225 (2,3)	M16x1,5 (9) /M16x1,5LH (9)	Ukraine, France, Lithuania, Latvia, Estonia	225.000.02
"DONMET" 225 (2,3)	G1/4 (6) - G3/8LH (8)	Poland, Bulgaria, Germany, Austria, Switzerland, Slovakia, Czech Republic, Hungary, Sweden, Norway, Romania	225.000.05
"DONMET" 225 (3,4)	M16x1,5 (9) /M16x1,5LH (9)	Ukraine, France, Lithuania, Latvia, Estonia	225.000.03
"DONMET" 225 (3,4)	G1/4 (6) - G3/8LH (8)	Poland, Bulgaria, Germany, Austria, Switzerland, Slovakia, Czech Republic, Hungary, Sweden, Norway, Romania	225.000.04

Welding torch | "DONMET" 251 | Palnik do spawania gazowego



ACETYLENE

	Welding capacity:	2 - 11 mm
	Grubość spawanego metalu:	2 - 11 mm
	Used gas fuel:	Acetylene (A)
	Gaz palny:	Acetylene (A)
	Scope of delivery:	gas welding tips No. 3,4,5
	Kompletacja:	gas welding tips No. 3,4,5
	Torch weight:	0.41 kg
	Waga:	0.41 kg
	Torch length:	400 mm (with No.3)
	Długość palnika:	400 mm (with No.3)

Item	Inlet connection (hose)	Country	Order No.
"DONMET" 251	M16x1,5 (9) /M16x1,5LH (9)	Greece, France, Ukraine, Lithuania, Latvia, Estonia	251.000.00
"DONMET" 251	G1/4 (6) - G3/8LH (8)	Poland, Bulgaria, Germany, Austria, Switzerland, Slovakia, Czech Republic, Hungary, Sweden, Norway, Romania, Serbia	251.000.01

Brazing torch | "DONMET" 228P | Palnik



Designed for brazing
of ferrous and non-ferrous metals

- seamless copper tip – good heat sink, long service life
- brazing in hard-to-reach places
- a perfect handle shape for convenient brazing
- light weight, convenience and mobility



Przeznaczony jest do
lutowania metali żelaznych i nieżelaznych

- bezszwowa końcówka z miedzi - dobre odprowadzanie ciepła, długa żywotność
- lutowanie w trudno dostępnych miejscach
- idealny kształt rękojeści do wygodnego lutowania
- lekkie, wygodne i łatwe w manewrowaniu

PROPANE



Used gas fuel: Gaz palny:	Propane-butane (P)
Scope of delivery: Kompletacja:	gas welding tips No. 2, 3
Torch weight: Waga:	0.3 kg
Torch length: Długość palnika:	390 mm (with No.3)



Item	Inlet connection (hose)	Country	Order No.
"DONMET" 228P	G1/4 (6) - G3/8LH (8)	Poland, Bulgaria, Germany, Austria, Switzerland, Slovakia, Czech Republic, Hungary, Scandinavia, Romania	228.000.04
"DONMET" 228P	M12x1,25(6) M12x1,25LH (6)	Ukraine, Lithuania, Latvia, Estonia	228.000.03
"DONMET" 228P	G1/4 (6) - G1/4LH (6)	Italy	228.000.05
"DONMET" 228P	M12x1 (6) /M12x1LH (6)	Greece, France	228.000.06

Brazing torch | "DONMET" 248P | Palnik



Designed for brazing
of ferrous and non-ferrous metals

- a perfect handle shape for convenient brazing
- light-weight, convenient and maneuverable



Przeznaczony jest do
lutowania metali żelaznych i nieżelaznych

- idealny kształt rękojeści do wygodnego lutowania
- lekkie, wygodne i łatwe w manewrowaniu

PROPANE



Used gas fuel: Gaz palny:	Propane-butane (P)
Scope of delivery: Kompletacja:	gas welding tips No. 2, 3 with forehearth
Torch weight: Waga:	0.3 kg
Torch length: Długość palnika:	390 mm (with No.3)



Item	Inlet connection (hose)	Country	Order No.
"DONMET" 248P	G1/4 (6) - G3/8LH (8)	Poland, Bulgaria, Germany, Austria, Switzerland, Slovakia, Czech Republic, Hungary, Scandinavia, Romania	248.000.03
"DONMET" 248P	M12x1 (6) /M12x1LH (6)	Greece, France,	248.000.06
"DONMET" 248P	M12x1,25(6) - M12x1,25LH (6)	Ukraine, Lithuania, Latvia, Estonia	248.000.02

Heating torch | "DONMET" 249 | Palnik do podgrzewania



- Designed for preliminary low- and high-temperature heating of products before welding of composite materials or surfacing
- Jest stosowany do wstępnego podgrzewania wyrobów przed spawaniem i napawaniem

	Used gas fuel:	Propane-butane (P)
	Gaz palny:	
	Scope of delivery:	gas welding tips No.6 with mesh nozzle
	Kompletacja:	
	Torch weight:	0.55 kg
	Waga:	
	Torch length:	540 mm
	Długość palnika:	



Item	Inlet connection (hose)	Country	Order No.
"DONMET" 249P	G1/4 (6) - G3/8LH (8)	Poland, Bulgaria, Germany, Austria, Switzerland, Slovakia, Czech Republic, Hungary, Scandinavia, Romania	249.000.03
"DONMET" 249P	M16x1,5 (9) /M16x1,5LH (9)	France, Ukraine, Lithuania, Latvia, Estonia	249.000.00

Heating torch | "DONMET" 262 | Palnik do podgrzewania

- Designed for heating of spare parts and raw parts made of ferrous and non-ferrous metals, surfacing of composite materials.
- Palnik przeznaczony jest do podgrzewania materiałów stalowych w procesach prostowania, usuwania deformacji itp. Może być również stosowany do podgrzewania materiału przy spawaniu, lutowaniu oraz wszystkich procesach pokrewnych wymagających silnego źródła ciepła.



	Used gas fuel:	Propane-butane (P)
	Gaz palny:	Methane (M) gaz ziemny
	Scope of delivery:	tip with mesh nozzle
	Kompletacja:	
	Torch weight:	1.2 / 1.45 kg
	Waga:	
	Torch length:	750 / 1150 mm
	Długość palnika:	

PROPANE

Item	Inlet connection (hose)	L, mm	Country	Order No.
"DONMET" 262P	G1/4 (6) - G3/8LH (8)	750	Poland, Bulgaria, Germany, Austria, Switzerland, Slovakia, Czech Republic, Hungary, Scandinavia, Romania	262.000.08
"DONMET" 262P		1150		262.000.09
"DONMET" 262P	M16x1,5 (9) /M16x1,5LH (9)	750	France, Ukraine, Lithuania, Latvia, Estonia	262.000.00
"DONMET" 262P		1150		262.000.01

Heating torch | "DONMET" 272 A | Palnik do podgrzewania

Designed for thermal straightening of metal structures after their welding, preliminary low- and high-temperature heating of items before welding, surfacing of hard non-ferrous alloys, welding of parts made of cast iron and non-ferrous metals and brazing with high-temperature solders.

Przeznaczony do termicznego prostowania konstrukcji metalowych po spawaniu, wstępnego nagrzewania przedmiotów w niskiej i wysokiej temperaturze przed spawaniem, napawania twardych stopów metali nieżelaznych, spawania części wykonanych z żeliwa i metali nieżelaznych oraz lutowania w wysokiej temperaturze lutowie

ACETYLENE



	Used gas fuel:	Acetylene
	Gaz palny:	Acetylene
	Scope of delivery:	tip with mesh nozzle
	Kompletacja:	tip with mesh nozzle
	Torch weight:	0,9 kg
	Waga:	0,9 kg
	Torch length:	725 mm
	Długość palnika:	725 mm

Item	Inlet connection (hose)	L, mm	Country	Order No.
"DONMET" 272A	G1/4 (6) - G3/8LH (8)	725	Poland, Bulgaria, Germany, Austria, Switzerland, Slovakia, Czech Republic, Hungary, Scandinavia, Romania	272.000.01
"DONMET" 272A	M16x1,5 (9) /M16x1,5LH (9)	725	Ukraine, Lithuania, Latvia, Estonia, France	272.000.00

Glass blowing torch | "DONMET" 215 LAMPWORK | Palnik szklarski do obróbki szkła

Glass blowing torch "DONMET" 215
Glass melting torch for small boro projects or soft glass.
Designed for: heating, brazing and shaping of objects made of glass (glass tubes, etc.).
Lamp worker torch can give all necessary types of flame – from small, hot pinpoint flames to large, wide, bushy flames and intermediate flames types.
The torch is installed at a desk or a test bench.
Flameworking torch DONMET 215-11 produces a nice quite long and stable fluffy flame with a good heat power.
You get a nice big working area and you can create any glass blowing applications from decorative beads to small hollow vessels.

Palnik szklarski do obróbki szkła "DONMET" 215
Palnik szklarski "DONMET" 215 przeznaczone do podgrzewania, lutowania i kształtowania przedmiotów wykonanych ze szkła (rurki szklane itp.).
Palnik instaluje się na biurku lub stanowisku testowym.
Palnik szklarski DONMET 215-11 wytwarza ładny, dość długi i stabilny puszysty płomień o dobrej mocy cieplnej.
Otrzymujesz ładny, duży obszar roboczy.
Można tworzyć dowolne aplikacje z dmuchania szkła, od ozdobnych koralików po małe, puste w środku naczynia.



PROPANE

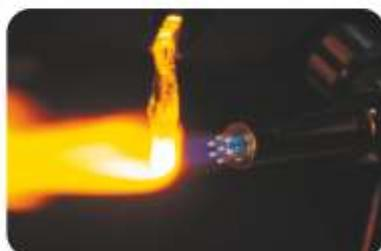

Item	Hose	Order No.
"DONMET" 215	6	215.000.11

Brazing torch | "DONMET" 297 | Palnik do lutowania gazowego



ideal for jewellery and dentoprosthetic works

GVP No.3

UK Purposed for:

- brazing during jewellery and dentoprosthetic works;
- brazing with soft and coarse solders with their melting temperature not exceeding 700°C, as well as for heating, melting and similar thermal processes.

PL Jest propanowo-powietrznym palnikiem przeznaczonym do lutowania miękkiego drobnych elementów ze stali i metali kolorowych. Zasilany propanem-butanem i powietrzem atmosferycznym. Może być również zastosowany do podgrzewania, opalania itp Moc cieplna zależy od wielkości nasadki, rodzaju gazu w butli i temp. otoczenia.

TECHNICAL SPECIFICATION		Propane-butane	Natural gas methane
Rate of heat flow, KW	GVP No.1	0,2 - 0,3	0,12 - 0,16
	GVP No.2	0,56 - 0,9	0,36 - 0,5
	GVP No.3	0,67 - 1,1	0,4 - 0,6
Torch length with tip GVP No.1, no more than, mm		260	
Torch weight with tip GVP No.1, no more than, kg		0,15	
Order No.		297.000.00	

Brazing torch | "DONMET" 254, 234 | Palnik do lutowania na propan-powietrze



UK Used gas fuel:	Propane-butane (P)
PL Gaz palny:	Methane (M) gaz ziemny
Heat flow power P/M:	
Siła strumienia cieplnego:	
tip GVP nasadka GVP	4.7 / 3.5 kW
tip No.0 nasadka No.0	6.1 / 5.3 kW
tip No.1 nasadka No.1	23.8 / 9.6 kW
Torch weight , no more than	0.55 / 0.45 kg
Waga: nie więcej niż	

UK Torch with gas fuel forced supply and air bleed from the atmosphere.

Designed for cable brazing, couplings crimping, household and facility-related works.

PL Do twardego i miękkiego lutowania. Przeznaczony do lutowania drobnych części

Item	Hose	Order No.
"DONMET" 254	8	254.000.02
"DONMET" 234	8	234.000.02

Brazing torch | "DONMET" 229 | Palnik do lutowania na propan-powietrze



 Torch with gas fuel forced supply and air bleed from the atmosphere.
Scope of use: heating and brazing of products made of ferrous and non-ferrous metals.

 **Do twardego i miękkiego lutowania.**
 Przeznaczony do lutowania drobnych części
 Zasilany propanem-butanem i powietrzem atmosferycznym.

	Used gas fuel:	Propane-butane (P)
	Gaz palny:	
	Heating temperature:	up to 700°C
	Temperatura lutowania:	
	Heat flow power:	up to 4.2 kW
	Siła strumienia cieplnego:	
	Torch weight , no more than	0.35 kg
	Waga: nie więcej niż	

Item	Hose	Order No.
"DONMET" 229	8	229.000.06

Brazing torch | "DONMET" 246 | Palnik do lutowania na propan-powietrze



 Torch with gas fuel forced supply and air bleed from the atmosphere.
Scope of use: heating and brazing of products made of ferrous and non-ferrous metals.

 **Do twardego i miękkiego lutowania.**
 Przeznaczony do lutowania drobnych części
 Zasilany propanem-butanem i powietrzem atmosferycznym.

	Used gas fuel:	Propane-butane (P)
	Gaz palny:	Methane (M) gaz ziemny
	Heating temperature:	up to 700°C
	Temperatura lutowania:	
	Heat flow power:	up to 4.7 / 2.6 kW
	Siła strumienia cieplnego:	
	Torch weight , no more than	0.21 kg
	Waga: nie więcej niż	

Item	Hose	Order No.
"DONMET" 246	8	246.000.03

Heating torch | "DONMET" 231 | Palnik na propan-powietrze

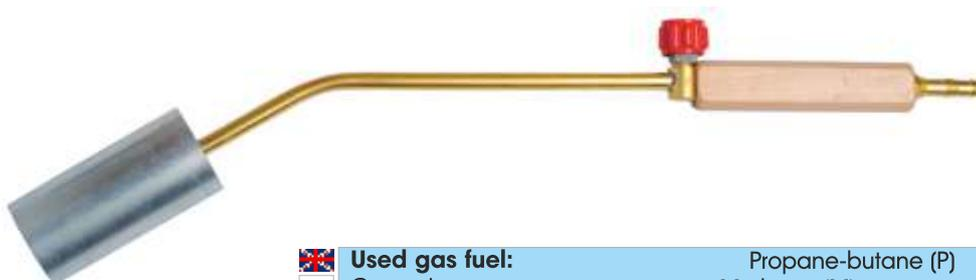

Torch with gas fuel forced supply and air bleed from the atmosphere.
Scope of use: household and facility-related works.

Zasilany propanem-butanem i powietrzem atmosferycznym
Przeznaczony do prac w gospodarstwie, np. opalania tusz zwierząt

	Used gas fuel:	Propane-butane (P)
	Gaz palny:	Methane (M) gaz ziemny
	Heat flow power P/M:	23.2 / 9.6 kW
	Siła strumienia ciepłego:	
	Torch weight , no more than	0.3 kg
	Waga: nie więcej niż	

Item	Hose	Nozzle	Length, mm	Order No.
"DONMET" 231	8	No.1	455	231.000.32

Heating torch | "DONMET" 231U | Palnik na propan-powietrze



Torch with gas fuel forced supply and air bleed from the atmosphere.
Scope of use: bituminous rolled materials washing, casting molds drying, etc.

Zasilany propanem-butanem i powietrzem atmosferycznym.
Znajduje zastosowanie w: pracach dekarских (podgrzewanie kładzionej papy);
w pracach przydomowych (rozmrzanie, likwidacja starych pokryć malowanych farbami).

	Used gas fuel:	Propane-butane (P)
	Gaz palny:	Methane (M) gaz ziemny
	Heat flow power P/M:	68 / 46 kW
	Siła strumienia ciepłego:	
	Torch weight , no more than	0.5 kg
	Waga: nie więcej niż	

Item	Hose	Nozzle	Length, mm	Order No.
"DONMET" 231U	8	No.4	870	231.000.34

Heating torch | "DONMET" 232 | Palnik na propan-powietrze



Torch with gas fuel forced supply and air bleed from the atmosphere.
Scope of use: bituminous rolled materials washing, casting molds drying, etc.

Zasilany propanem-butanem i powietrzem atmosferycznym.
Znajduje zastosowanie w: pracach dekarских (podgrzewanie kładzionej papy);
w pracach przydomowych (rozmrzanie, likwidacja starych pokryć malowanych farbami).

	Used gas fuel:	Propane-butane (P)
	Gaz palny:	Methane (M) gaz ziemny
	Heat flow power P/M:	68 / 46 kW
	Siła strumienia ciepłego:	
	Torch weight , no more than	0.5 kg
	Waga: nie więcej niż	

Item	Hose	Nozzle	Length, mm	Order No.
"DONMET" 232U	8	No.4	870	232.000.04
"DONMET" 232	8	No.4	560	232.000.06

Heating torch | "DONMET" 252 | Palnik na propan-powietrze



	Used gas fuel: Gaz palny:	Propane-butane (P) Methane (M) gaz ziemny
	Heat flow power P/M: Siła strumienia ciepłego:	up to 96 / 61 kW
	Torch weight , no more than Waga: nie więcej niż	0.95 kg

Torch with gas fuel forced supply and air bleed from the atmosphere.

Scope of use: bituminous rolled materials washing, casting molds drying etc.

Item	Hose	Nozzle	Length, mm	Order No.
"DONMET" 252	8	No. 4	920	252.000.01

Heating torch | "DONMET" 263 | Palnik na propan-powietrze

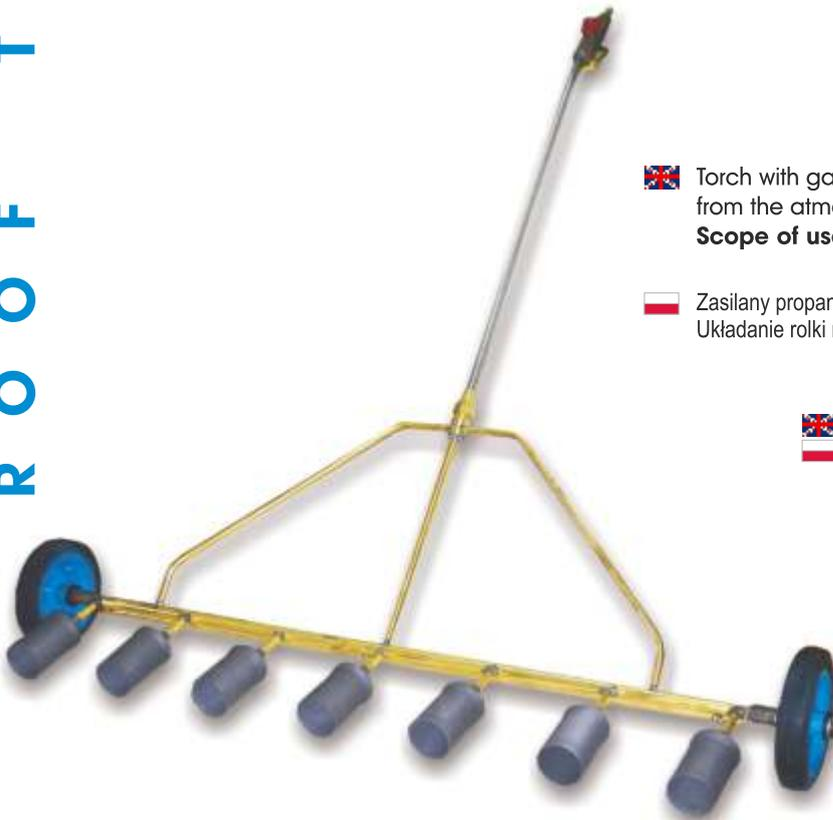

Torch with gas fuel forced supply and air bleed from the atmosphere.

Scope of use: placement of surfacing rolled roof and waterproof material.

Zasilany propanem-butanem i powietrzem atmosferycznym.
Układanie rolki materiału spoiny na powierzchni dachu.

	Used gas fuel: Gaz palny:	Propane-butane (P)
	Gas fuel consumption: Zużycie gazu:	18.8 - 25.1 kg/h*
	Pressure: Ciśnienie:	2-3 bar
	Heat flow power (nozzle No. 4x7): Siła strumienia ciepłego:	315.7 - 429.2 kW
	Grasp width: Szerokość robocza:	1000 mm
	Torch weight , no more than Waga: nie więcej niż	5,2 kg

***Note:** 1 kg of liquefied propane-butane generates approximately 500 l of gas during evaporation

To fully take advantage of the torch capabilities it is recommended to connect the torch to four cylinders with propane-butane simultaneously as working with one cylinder does not ensure the required gas consumption.

Item	Hose	Nozzle	Order No.
"DONMET" 263	8	No. 4	263.000.02

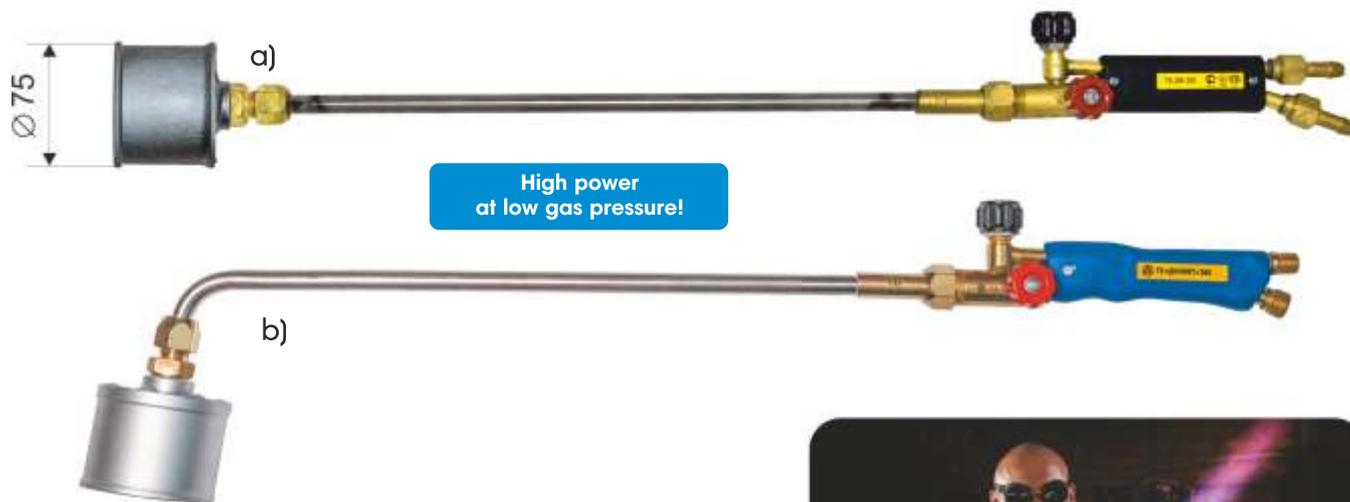

	Used gas fuel:	Propane-butane (P)
	Gaz palny:	Methane (M) gaz ziemny
	Heat flow power P/M:	up to 57 / 42 kW
	Moc cieplna:	up to 57 / 42 kW
	Flame length:	330 - 800 mm
	Długość płomienia:	330 - 800 mm
	Pressure:	
	Ciśnienie robocze:	
	Compressed air	3 - 5 bar
	Sprężone powietrze	3 - 5 bar
	Natural gas (methane)	0.025...0.1 bar
	Gaz ziemny	0.025...0.1 bar
	Propane-butane	0.1...0.3 bar
	Propan-butan	0.1...0.3 bar
	Consumption, no more than:	
	Zużycie:	
	Compressed air	12 m ³ /h
	Sprężone powietrze	12 m ³ /h
	Natural gas (methane)	6 m ³ /h
	Gaz ziemny	6 m ³ /h
	Propane-butane	1.7 m ³ /h (3.4 kg/h)
	Propan-butan	1.7 m ³ /h (3.4 kg/h)
	Flame temperature:	1870°C
	Temperatura płomienia:	1870°C
	Torch length, no more than:	785 / 1185 mm
	Długość palnika:	785 / 1185 mm
	Torch weight, no more than:	1.16 / 1.4 kg
	Waga:	1.16 / 1.4 kg

Torch with compressed air forced supply.

Designed for:

- heating of products made of ferrous and non-ferrous metals, non-metallic materials;
- preliminary heating before surfacing and welding;
- elimination of welding deformations and stresses;
- heating of parts at assembly (disassembly), heavy-shrink fitting;
- washing of bituminous rolled materials surface during the production of waterproof material and rolled roofing material;
- drying of casting molds, reinforced concrete panels and brick laying;
- flame treatment of farm animals carcasses.

Palnik wysokiej mocy pracujący na niskim ciśnieniu gazu.

Prosty i wygodny. Palnik z wymuszonym dopływem powietrza.

Przeznaczenie:

- ogrzewanie wyrobów z metali żelaznych i nieżelaznych, materiałów niemetalicznych;
- podgrzewanie poprzednie do napawanie i spawanie;
- rozwiązywanie spawalniczych naprężeń i odkształceń;
- ogrzewanie części podczas montażu (demontażu) pasowania z wciskiem;
- napawanie powierzchni bitumu walcowanego przy produkcji hydroizolacji i miękkiego dachu;
- suszenie form, paneli żelbetowych i murów ceglanych;
- przetwarzanie ogniem tusz zwierząt gospodarskich.

Item	Hose	Length, mm	Order No.
a) "DONMET" 280	6/8	785	280.000.02
a) "DONMET" 280	6/8	1185	280.000.03
a) "DONMET" 280	9/9	785	280.000.00
b) "DONMET" 280	6/8	785	280.000.05
b) "DONMET" 280	9/9	1185	280.000.06



Natural gas
+ compressed air
= 63 kW of heat flow

	Used gas fuel:	Methane (M) gaz ziemny
	Gaz palny:	
	Heat flow power:	up to 63 kW
	Moc cieplna:	
	Flame length:	300 - 700 mm
	Długość płomienia:	
	Pressure:	
	Ciśnienie robocze:	
	Compressed air	3 - 8 bar
	Sprężone powietrze	
	Natural gas (methane)	0.025...2.0 bar
	Gaz ziemny	
	Consumption, no more than:	
	Zużycie:	
	Compressed air	36.9 m ³ /h
	Sprężone powietrze	
	Natural gas (methane)	6.6 m ³ /h
	Gaz ziemny	
	Flame temperature:	1870°C
	Temperatura płomienia:	
	Torch length, no more than:	1370 mm
	Długość palnika:	
	Torch weight, no more than:	4.6 kg
	Waga:	

Torch with forced supply of compressed air.

Designed for:

- heating of products made of ferrous and non-ferrous metals, non-metallic materials;
- preliminary heating before surfacing and welding;
- elimination of welding deformations and stresses;
- heating of parts at assembly (disassembly), heavy-shrink fitting;
- drying of casting molds, reinforced concrete panels and brick laying.

The torch is to be installed fixedly.

Palnik Wysokiej Mocy pracujący na niskim ciśnieniu Gazu. Palnik Z wymuszonym dopływem POWIETRZA.

Przeznaczenie:

- ogrzewanie wyrobów z metali żelaznych i nieżelaznych, materiałów niemetalicznych;
- podgrzewanie poprzednie do napawanie i spawanie;
- rozwiązywanie spawalniczych naprężeń i odkształceń;
- ogrzewanie części podczas montażu (demontażu) pasowania z wciskiem;
- suszenie form, paneli żelbetowych i murów ceglanych

Item	Hose	Order No.
a) "DONMET" 275	12/12	275.000.00
b) "DONMET" 275	12/12	275.000.01

Torches for flame straightening | "DONMET" 276 | Palniki do prostowania metali

The torches are intended for manual heating of flat surfaces of carbon and alloy steel, non-ferrous metals, grey iron. They are widely used for thermal straightening of metal with a flat surface as well as for post-weld stress relief.

- ▶ the metal is heated in a strictly limited area in a short space of time
- ▶ high temperature and heat flow rate
- ▶ versions designed for operating on acetylene, propane and methane
- ▶ number of nozzles from 2 up to 10
- ▶ torch customization to your specific requirements

Przeznaczone do ręcznego ogrzewania płaskich powierzchni ze stali węglowych i stopowych, metali nieżelaznych, żeliwa. Jest szeroko stosowany do termicznego prostowania metalu o płaskiej powierzchni i łagodzenia naprężeń resztkowych w metalu po spawaniu.

- ▶ metal jest ogrzewany na ściśle ograniczonym obszarze w krótkim czasie
- ▶ wysoka temperatura i moc cieplna
- ▶ modyfikacje do pracy z acetylenem, propanem lub metanem
- ▶ liczba dysz od 2 do 10
- ▶ możliwość wykonania palnika według indywidualnych Państwa wymagań

TECHNICAL SPECIFICATION

Breadth of the metal to be heated, B, mm		100	130	160	300
Pressure, kgf/cm ²	oxygen	2,0 - 4,0			4,0 - 6,0
	acetylene	0,2 - 1,2			
	propane-butane				0,02 - 1,0
	methane	0,03 - 1,5			
Consumption, m ³ /h	oxygen	2,6 - 4,12			2,3 - 3,0
	acetylene	2,34 - 3,7			
	propane-butane				0,5 - 0,7
	methane	3,0 - 3,1			
Oxygen connector (hose)		G $\frac{1}{4}$ (6)			
Fuel gas connector (hose)		G $\frac{3}{8}$ LH(8)			
Torch length no more than, mm		1125			1000
Torch weight no more than, kg		1,3	1,5	1,7	3,1

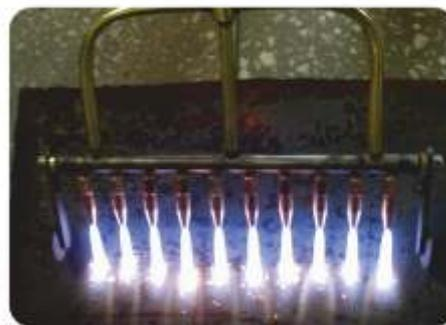

Item	Breadth, B, mm	Number of nozzles	Order No.
"DONMET" 276 A	100	2	276.000.24
"DONMET" 276 A	130	3	276.000.13
"DONMET" 276 A	160	4	276.000.14
"DONMET" 276 P, M	300	10	276.000.23
"DONMET" 276 P	130	3	276.000.17
"DONMET" 276 P	160	4	276.000.18
"DONMET" 276 P	100	2	276.000.16
"DONMET" 276 P, M	160	6	276.000.19



For installation to cutting torch (welding torch) | Bezpieczniki przypalnikowe

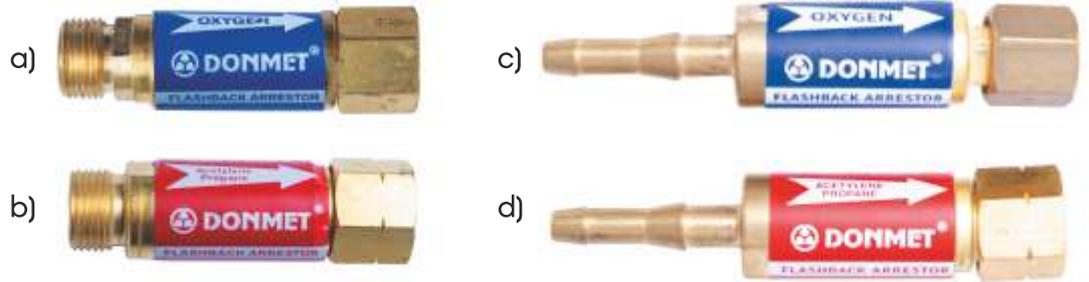

Type	Gas	Maximum working pressure, bar	Rated capacity, m ³ /hour	Thread (hose)	Order No.
a) KOK	oxygen	20	60	G $\frac{1}{4}$ - G $\frac{1}{4}$	950.000.03
		20	60	G $\frac{3}{8}$ - G $\frac{3}{8}$	950.000.04
		20	60	M12x1,25 - M12x1,25	950.000.00
		20	60	M16x1,5 - M16x1,5	950.000.02
c) KOK		20	60	G $\frac{1}{4}$ - hose Ø6/8	950.000.59
b) KOG	acetylene propane methane MAPP	3	15	G $\frac{3}{8}$ LH - G $\frac{3}{8}$ LH	950.000.09
		3	15	M16x1,5LH - M16x1,5LH	950.000.07
		3	15	M12x1,25LH - M12x1,25LH	950.000.05
d) KOG		3	15	G $\frac{3}{8}$ LH - hose Ø6/8	950.000.61

For installation in hose rupture place | Bezpieczniki zainstalowane w węźle

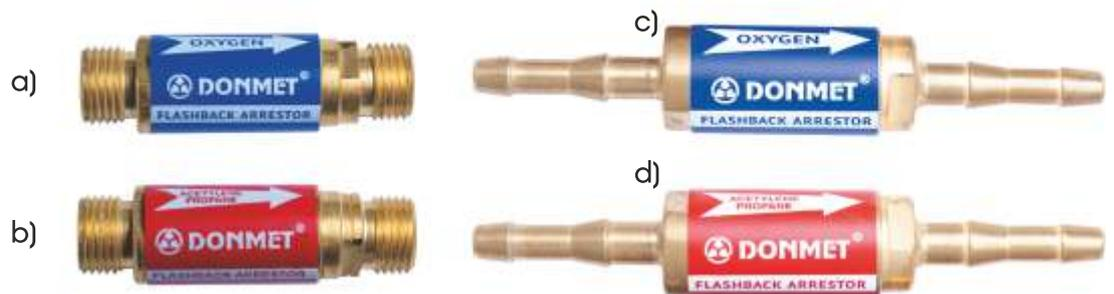

Type	Gas	Maximum working pressure, bar	Rated capacity, m ³ /hour	Thread (hose)	Order No.
a) KOK	oxygen	20	60	G $\frac{1}{4}$ - G $\frac{1}{4}$	950.000.13
		20	60	M16x1,5 - M16x1,5	950.000.12
		20	60	M12x1,25 - M12x1,25	950.000.10
c) KOK		20	60	hose 6/8 - hose 6/8	950.000.54
b) KOG	acetylene propane methane MAPP	3	15	G $\frac{3}{8}$ LH - G $\frac{3}{8}$ LH	950.000.19
		3	15	M16x1,5LH - M16x1,5LH	950.000.17
		3	15	M12x1,25LH - M12x1,25LH	950.000.15
d) KOG		3	15	hose 6/8 - hose 6/8	950.000.55

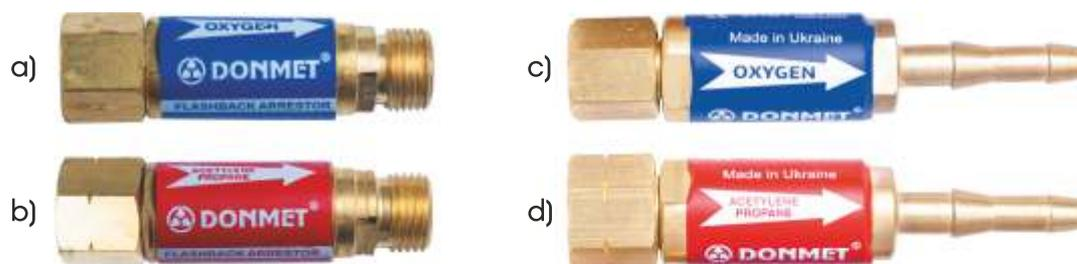

Type	Gas	Maximum working pressure, bar	Rated capacity, m ³ /hour	Thread (hose)	Order No.
a) KOK	oxygen	20	60	G ¹ / ₄ - G ¹ / ₄	950.000.23
		20	60	G ³ / ₈ - G ³ / ₈	950.000.24
		20	60	M16x1,5 - M16x1,5	950.000.22
		20	60	M12x1,25 - M12x1,25	950.000.20
c) KOK		20	60	G ¹ / ₄ - hose Ø6/8	950.000.56
b) KOG	acetylene propane methane	3	15	G ³ / ₈ LH - G ³ / ₈ LH	950.000.29
		3	15	M16x1,5LH - M16x1,5LH	950.000.27
		3	15	M12x1,25LH - M12x1,25LH	950.000.25
d) KOG	MAPP	3	15	G ³ / ₈ LH - hose Ø6/8	950.000.58

Network flashback arrestor "DONMET" | Sieciowe zawory ognioochronne



Designed for gas stations (gas pipelines) protection from rupture and inflammations during flashbacks.

It's installed to gas stations (gas pipelines) supplying increased power cutting torches DONMET.

Dla ochrony złącz gazowych (gazociągów) od podziałów i pożaru przy zwrotnych uderzeniach płomienia.

Arrow shows gas direction to the consumer!

Type	Gas	Maximum working pressure, bar	Rated capacity, m ³ /hour	Thread	Order No.
a) KOK	oxygen	20	120	G ³ / ₄	955.000.02
b) KOG	acetylene propane methane	3.0	30	G ³ / ₄	955.000.01
b) KOG	propane methane	3.0	30	G ³ / ₄	955.000.03

Oxygen pressure regulator | DONMET RO-200-2 DM mini | Reduktor butlowy do tlenu

	Maximum capacity: Nominalna przepustowość:	50 m ³ /h
	Maximum gas inlet pressure: Ciśnienie wlotowe:	200 bar
	Maximum gas working pressure: Ciśnienie wylotowe:	12.5 bar
	Weight, no more than: Waga:	0.8 kg

-  **"Mini" series**
- light weight and small size, and yet great performance
 - for fixed and portable gas stations
 - pressure gauge diameter 50mm
 - inlet pressure up to 200bar
 - safety valve
 - coloured according to the gas type
 - easily serviced
 - low price
 - 12-month warranty

-  **Seria "mini"**
- lekka waga, mały rozmiar z dobrą wydajnością
 - do stacjonarnych i przenośnych stanowisk spawalniczych
 - manometry o średnicy 50mm
 - ciśnienie wejściowe do 200 barów
 - zawór bezpieczeństwa
 - kolor według rodzaju gazu
 - łatwe w utrzymaniu
 - niska cena
 - 1 rok gwarancji

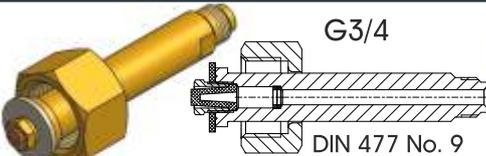
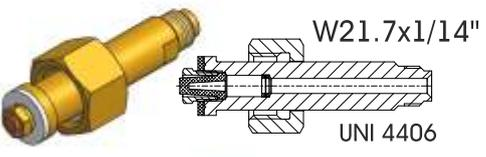
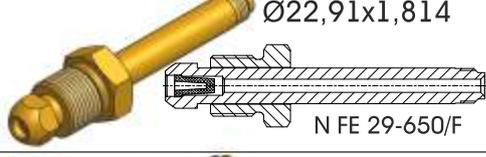
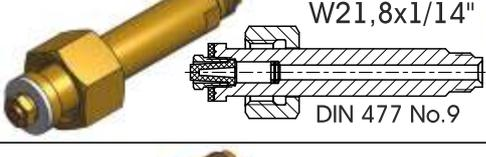
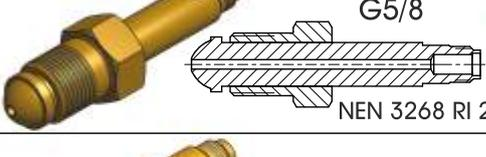
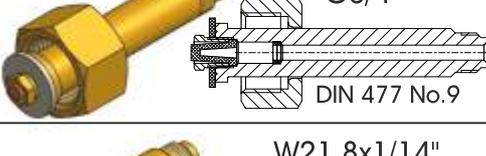
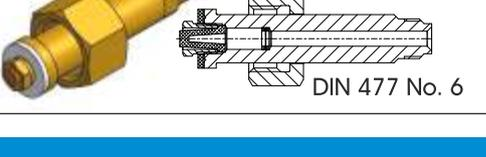

Item	Inlet connection	Outlet connection	Country	Order No.
RO-200-2 DM mini	 G3/4 DIN 477 No. 9	 G1/4, 6E	Poland, Bulgaria, Germany, Austria, Switzerland, Czech Republic, Slovakia, Hungary, Scandinavia	006.000.10
RO-200-2 DM mini	 W21.7x1/14" UNI 4406	 G3/8, 6/9	Finland, Italy	006.000.21
RO-200-2DM mini	 Ø22,91x1,814 N FE 29-650/F	 16x150D (R) 6/10	France	006.000.40
RO-200-2DM mini	 W21,8x1/14" DIN 477 No.9	 G1/4, 6E	Slovakia, Slovenia	006.000.14
RO-200-2DM mini	 G5/8 NEN 3268 RI 2	 G1/4, 6E	Belgium, Netherlands	006.000.44
BKO-50DM GOST	 G3/4 DIN 477 No.9	 M16x1,5 6/9	Lithuania, Latvia, Estonia, Ukraine	006.000.00
BKO-50DM GOST	 W21,8x1/14" DIN 477 No. 6	 M16x1,5 6/9	Lithuania, Latvia, Estonia, Ukraine	006.000.03

	Maximum capacity: Nominalna przepustowość:	50 m ³ /h
	Maximum gas inlet pressure: Ciśnienie wlotowe:	200 bar
	Maximum gas working pressure: Ciśnienie wylotowe:	12.5 bar
	Weight, no more than: Waga:	0.9 kg

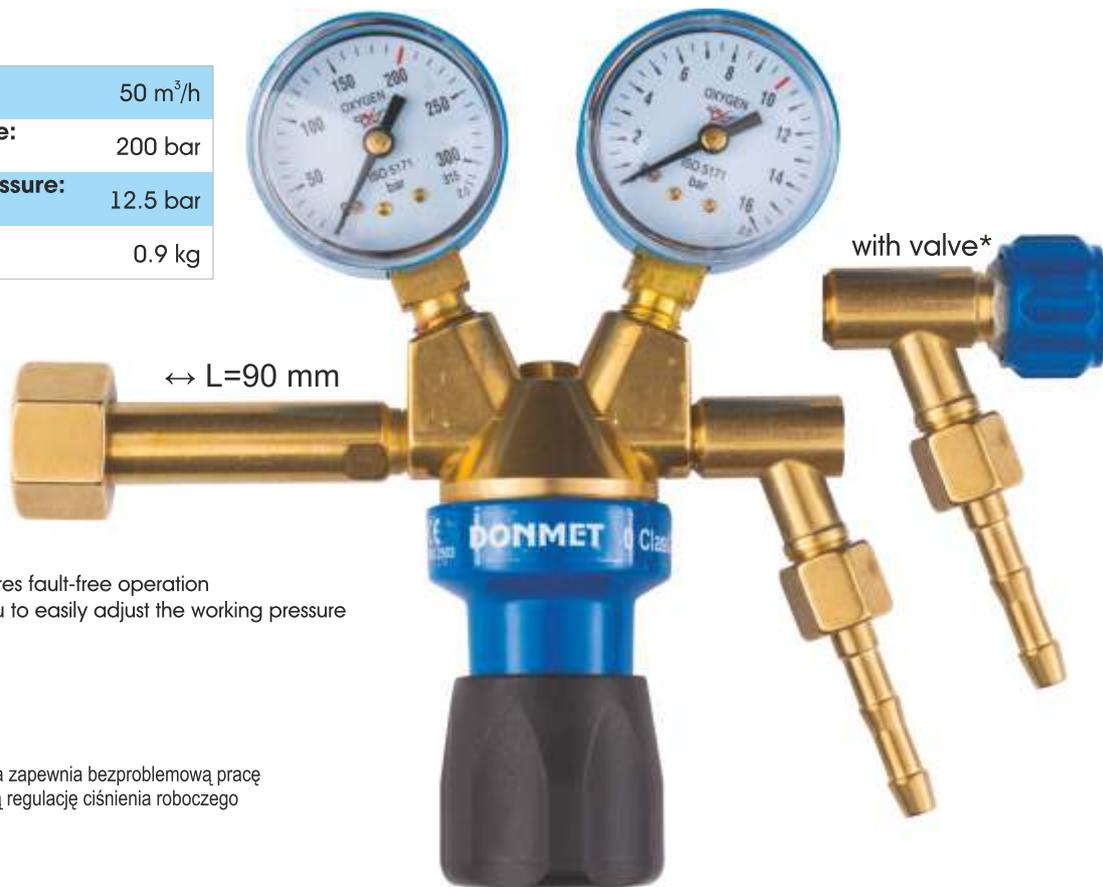

"Vertical" series

- durable reducing unit ensures fault-free operation
- convenient knob allows you to easily adjust the working pressure
- 3-year warranty

Seria "pionowe"

- Wytrzymała jednostka redukująca zapewnia bezproblemową pracę
- wygodny zawór pozwala na łatwą regulację ciśnienia roboczego
- 3 lata gwarancji

Item	Inlet connection	Outlet connection	Country	Order No.
RO-200-V DM with valve*	 G3/4 DIN 477 No. 9	 G1/4, 6E	Poland, Bulgaria, Germany, Austria, Switzerland, Czech Republic, Slovakia, Hungary, Scandinavia	060.000.06 060.000.07*
RO-200-V DM with valve*	 G5/8 BS 341-3	 G1/4, 6E	Portugal, Great Britain	060.000.01 060.000.04*
RO-200-V DM with valve*	 W21.7x1/4" UNI 4406	 G3/8, 8E	Finland, Italy	060.000.21 060.000.27*
RO-200-V DM	 G5/8 BS 341-3	 M16x1,5, 6/9	Greece	060.000.30
RO-200-V DM with valve*	 Ø22,91x1,814 N FE 29-650/F	 16x150D (R), 6/10	France	060.000.42 060.000.40*
RO-200-V DM	 G5/8 NEN3268 RI 2	 G1/4, 6	Belgium, Netherlands	060.000.44

Oxygen pressure regulator | RO-200-2 DM | Reduktor butlowy do tlenu

	Maximum capacity: Znamionowa przepustowość:	50 m ³ /h
	Maximum gas inlet pressure: Znamionowe ciśnienie wlotowe:	200 bar
	Maximum gas working pressure: Zakres ciśnień wylotowych:	10.0 bar
	Weight, no more than: Waga:	1.3 kg

- highest performance
- large membrane ensures accurate maintenance of working pressure when the cylinder pressure drops
- pressure gauges Ø63mm according to ISO 5171
- reliable reducing unit
- inlet pressure up to 200bar
- safety valve
- coloured according to the type of gas
- durable
- 3-year warranty

- najwyższa wydajność
- duża membrana zapewnia precyzyjne utrzymywanie ciśnienia roboczego, gdy ciśnienie w butle spada
- manometry o średnicy 63 mm zgodnie z ISO 5171
- niezawodna jednostka redukująca
- ciśnienie wejściowe do 200 barów
- zawór bezpieczeństwa
- kolor według rodzaju gazu
- długotrwały
- 3 lata gwarancji



Item	Inlet connection	Outlet connection	Country	Order No.
RO-200-2 DM	G3/4 DIN 477 No. 9	G1/4, 6E	Poland, Bulgaria, Germany, Austria, Switzerland, Czech Republic, Slovakia, Hungary, Scandinavia	044.000.10
RO-200-2 DM	G5/8 W22.91x1/4" BS 341-3 / MiE AP7	G1/4, 6E	Portugal, Great Britain	044.000.14
RO-200-2 DM	W21.8x1/4" DIN 477 No. 6	G1/4, 6E	Lithuania, Latvia, Estonia, Ukraine	044.000.13
RO-200-2 DM	W21.8x1/4" DIN 477 No. 6	M16x1,5, 9	Lithuania, Latvia, Estonia, Ukraine	044.000.12
RO-200-2 DM	W21.7x1/4" UNI 4406	G3/8, 6/9	Finland, Italy	044.000.16
RO-200-2 DM	Ø22,91x1,814 N FE 29-650/F	16x150D (R), 6/10	France	044.000.40
RO-200-2 DM	G5/8 NEN3268 RI 2	G1/4, 6	Belgium, Netherlands	044.000.44

	Maximum capacity: Nominalna przepustowość:	5 m ³ /h
	Maximum gas inlet pressure: Ciśnienie wlotowe:	25 bar
	Maximum gas working pressure: Ciśnienie wylotowe:	4.0 bar
	Weight, no more than: Waga:	0.5 kg



- “Mini” series**
- light weight and small size, and yet great performance
 - for fixed and portable gas stations
 - pressure gauge diameter 50mm
 - coloured according to the gas type
 - easily serviced
 - low price
 - 12-month warranty

- Seria “mini”**
- lekka waga, mały rozmiar z dobrą wydajnością
 - do stacjonarnych i przenośnych stanowisk spawalniczych
 - manometry o średnicy 50mm
 - kolor według rodzaju gazu
 - łatwe w utrzymaniu
 - niska cena
 - 1 rok gwarancji

Item	Inlet connection	Outlet connection	Country	Order No.
RP-25 DM mini	W21.8x1/14" LH DIN 477 No. 1	G3/8LH, 8E	Bulgaria, Germany, Austria, Switzerland, Czech Republic, Slovakia, Hungary, Scandinavia	008.000.10
RP-25 DM mini	W21.8x1/14" LH Pin DIN 477 No. 2 Type KLF	G3/8LH, 8E	Poland	008.000.12
RP-25 DM mini	W20 x 1/14" LH UNI 4505/P	G3/8LH, 6/9	Italy, Austria	008.000.14
RP-25 DM mini	Ø21,7x1,814 LH N FE 29-650/E	16x150G LH, 10	France	008.000.40
BPO-5DM GOST	W21.8x1/14" LH DIN 477 No.1	M16x1,5LH, 6/9	Lithuania, Latvia, Estonia, Ukraine	008.000.02

	Maximum capacity: Znamionowa przepustowość:	5 m ³ /h
	Maximum gas inlet pressure: Znamionowe ciśnienie wlotowe:	25 bar
	Maximum gas working pressure: Zakres ciśnień wylotowych:	4.0 bar
	Weight, no more than: Waga:	1.1 kg



- highest performance
- large membrane ensures accurate maintenance of working pressure when the cylinder pressure drops
- pressure gauges Ø 63mm according to ISO 5171
- reliable reducing unit
- coloured according to the type of gas
- durable
- 3-year warranty

- najwyższa wydajność
- duża membrana zapewnia precyzyjne utrzymywanie ciśnienia roboczego, gdy ciśnienie w butle spada
- manometry o średnicy 63 mm zgodnie z ISO 5171
- niezawodna jednostka redukująca
- kolor według rodzaju gazu
- długotrwały
- 3 lata gwarancji

Item	Inlet connection	Outlet connection	Country	Order No.
RP-25 DM	W21.8x1/14" LH DIN 477 No. 1	G3/8LH, 8E	Bulgaria, Germany, Austria, Switzerland, Czech Republic, Slovakia, Hungary, Scandinavia	035.000.10
RP-25 DM	W21.8x1/14" LH Pin DIN 477 No. 2 Type KLF	G3/8LH, 8E	Poland	035.000.17
RP-25 DM	W21.8x1/14" LH DIN 477 No. 1	M16x1,5LH, 9	Lithuania, Latvia, Estonia, Ukraine	035.000.11
RP-25 DM	W20 x 1/14" LH UNI 4505/P	G3/8LH, 6/9	Italy, Austria	035.000.18
RP-25 DM	Ø21,7x1,814 LH N FE 29-650/E	16x150G LH, 10	France	035.000.40
BPO-5-4DM GOST	W21,8x1/14" LH DIN 477 No.1	M16x1,5LH, 6/9	Lithuania, Latvia, Estonia, Ukraine	035.000.00

Propane pressure regulator | DONMET RP-25 DM10 mini | Reduktor butlowy do propan-butanu

Propane pressure regulator with a constant gas working pressure. Ideal for delivering propane-butane to air torches.

Reduktor ze stale określonym ciśnieniem roboczym do zasilania palników gazowo-powietrznych propan-butan.

	Maximum capacity: Nominalna przepustowość:	5 m ³ /h
	Maximum gas inlet pressure: Ciśnienie wlotowe:	25 bar
	Maximum gas working pressure: Ciśnienie wylotowe:	2.0 bar
	Weight, no more than: Waga:	0.4 kg



Item	Inlet connection	Outlet connection	Country	Order No.
RP-25 DM10 mini	W21.8x1/14" LH DIN 477 No. 1	G3/8LH, 8E	Bulgaria, Germany, Austria, Switzerland, Czech Republic, Slovakia, Hungary, Scandinavia	010.000.04
RP-25 DM10 mini	W21.8x1/14" LH Pin DIN 477 No. 2 Type KLF	G3/8LH, 8E	Poland	010.000.06
RP-25 DM10 mini	Ø21,7x1,814 LH N FE 29-650/E	16x150G LH, 10	France	010.000.07
BPO-5DM-10 GOST	W21.8x1/14" LH DIN 477 No.1	M16x1,5LH, 6/9	Lithuania, Latvia, Estonia, Ukraine	010.000.02

Acetylene pressure regulator | RA-25 DM AGA | Reduktory butlowe do acetylenu

"Mini" series

- light weight and small size, and yet great performance
- for fixed and portable gas stations
- pressure gauge diameter 50mm
- coloured according to the gas type
- easily serviced
- low price
- 12-month warranty

Seria "mini"

- lekka waga, mały rozmiar z dobrą wydajnością
- do stacjonarnych i przenośnych stanowisk spawalniczych
- manometry o średnicy 50mm
- kolor według rodzaju gazu
- łatwe w utrzymaniu
- niska cena
- 1 rok gwarancji

	Maximum capacity: Znamionowa przepustowość:	5.0 m ³ /h
	Maximum gas inlet pressure: Znamionowe ciśnienie wlotowe:	25 bar
	Maximum gas working pressure: Zakres ciśnień wylotowych:	1.5 bar
	Weight, no more than: Waga:	0.8 kg



Item	Inlet connection	Outlet connection	Country	Order No.
RA-25 DM AGA	G3/4RH DIN 477 No.12	G3/8LH, 8E	Finland, Ukraine, Lithuania, Latvia, Estonia	015.000.15

Acetylene pressure regulator | RA-25-V DM | Reduktory butlowe do acetylenu

	Maximum capacity: Znamionowa przepustowość:	5.0 m ³ /h
	Maximum gas inlet pressure: Znamionowe ciśnienie wlotowe:	25 bar
	Maximum gas working pressure: Zakres ciśnień wylotowych:	1.5 bar
	Outlet thread: Gwint wylotowy:	G3/8
	Hose, Dy: Średnica węży:	8
	Weight, no more than: Waga:	1.5 kg

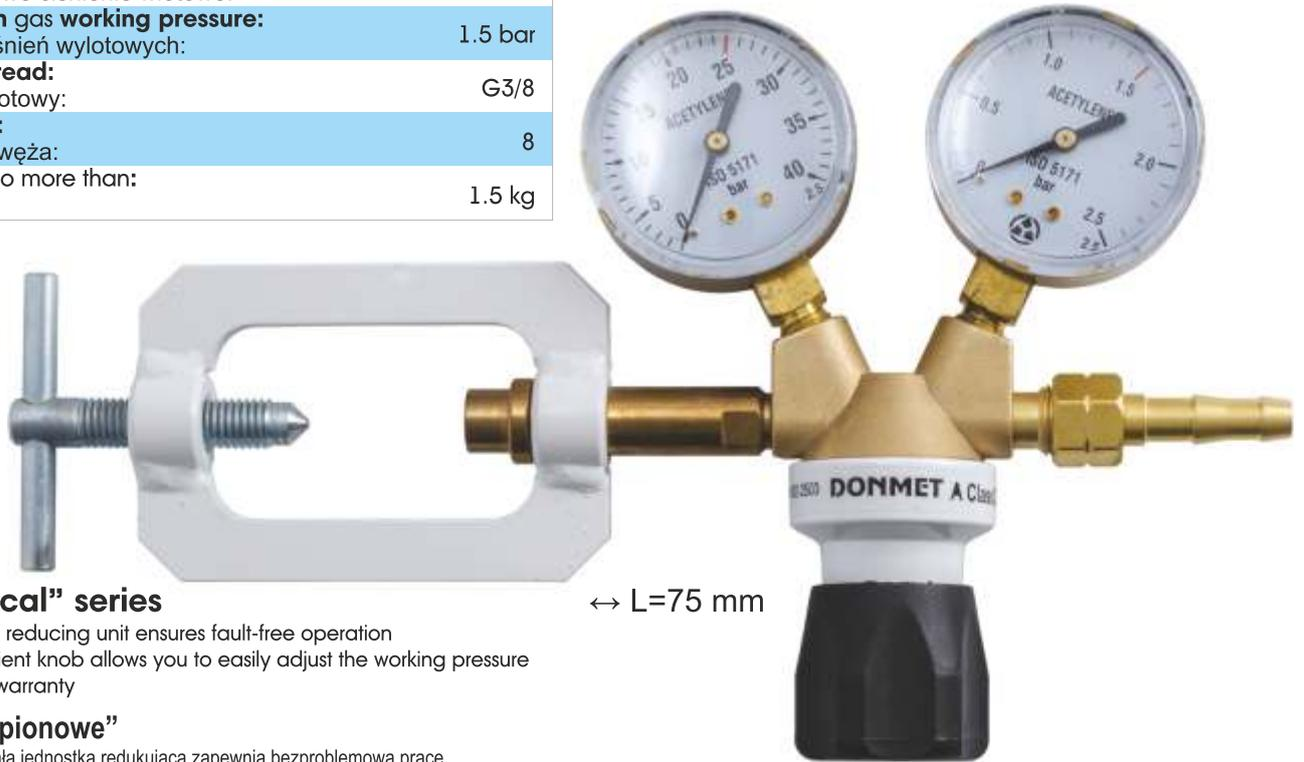

"Vertical" series

- durable reducing unit ensures fault-free operation
- convenient knob allows you to easily adjust the working pressure
- 3-year warranty

Seria "pionowe"

- Wytrzymała jednostka redukująca zapewnia bezproblemową pracę
- wygodny zawór pozwala na łatwą regulację ciśnienia roboczego
- 3 lata gwarancji

Item	Inlet connection	Outlet connection	Country	Order No.
RA-25-V DM	Yoke DIN 477 No.3	G3/8LH, 8E	Bulgaria, Germany, Austria, Switzerland, Czech Republic, Slovakia, Hungary, Scandinavia	062.000.00
RA-25-V DM	G5/8LH BS 341-2	G3/8LH, 8E	Portugal, Great Britain	062.000.02
RA-25-V DM	G3/4RH SFS 2322	G3/8LH, 8E	Finland, Ukraine, Lithuania, Latvia, Estonia	062.000.07
RA-25-V DM	G5/8LH UNI 4411/2	G3/8LH, 6/9	Italy	062.000.09
RA-25-V DM	Yoke Ø21xØ10mm N FE 29-650/A	16x150G(L), 6/10	Greece, France	062.000.11
RA-25-V DM	Ø22,91x1,814LH N FE 29-650/H	16x150 G (L), 10	France	062.000.42
RA-25-V DM	Yoke Ø20x9 NEN3268	G3/8LH, 8	Belgium, Netherlands	062.000.12

Acetylene pressure regulator | RA-25 DM | Reduktory butlowe do acetylenu

	Maximum capacity: Znamionowa przepustowość:	5.0 m ³ /h
	Maximum gas inlet pressure: Znamionowe ciśnienie wlotowe:	25 bar
	Maximum gas working pressure: Zakres ciśnień wylotowych:	1.5 bar
	Weight, no more than: Waga:	1.5 kg



- highest performance
- large membrane ensures accurate maintenance of working pressure when the cylinder pressure drops
- pressure gauges Ø63mm according to ISO 5171
- reliable reducing unit
- coloured according to the type of gas
- durable
- 3-year warranty

- najwyższa wydajność
- duża membrana zapewnia precyzyjne utrzymywanie ciśnienia roboczego, gdy ciśnienie w butle spada
- manometry o średnicy 63 mm zgodnie z ISO 5171
- niezawodna jednostka redukująca
- kolor według rodzaju gazu
- długotrwały
- 3 lata gwarancji

Item	Inlet connection	Outlet connection	Country	Order No.
RA-25 DM	 Yoke DIN 477 No.3	 G3/8LH, 8E	Bulgaria, Germany, Austria, Switzerland, Czech Republic, Slovakia, Hungary, Scandinavia	036.000.10
RA-25 DM	 G5/8LH BS 341-2	 G3/8LH, 8E	Portugal, Great Britain	036.000.12
RA-25 DM	 G3/4RH SFS 2322	 G3/8LH, 8E	Finland, Ukraine, Lithuania, Latvia, Estonia	036.000.15
RA-25 DM	 G5/8LH UNI 4411/2	 G3/8LH, 6/9	Italy	036.000.16
RA-25 DM	 UNI 11144 Uscifa No.7S	 G3/8LH, 6/9	Italy	036.000.17
RA-25 DM	 Ø22,91x1,814LH N FE 29-650/H	 16x150G LH, 10	France	036.000.41
RA-25 DM	 Ø22,91x1,814LH N FE 29-650/A	 16x150G LH, 10	France	036.000.40
BAO-5-4DM	 G3/4RH SFS 2322	 M16x1,5LH, 6/9	Finland, Ukraine, Lithuania, Latvia, Estonia	036.000.01

Inlet gas pressure (maximum): Ciśnienie wlotowe:	20 (200) MPa (bar)
Maximum capacity at maximum working pressure: Znamionowa przepustowość:	
- Ar	24 l/min
- CO ₂	22.5 l/min
Weight, no more than Waga:	0.8 kg



"Mini" series

- light weight and small size, and yet great performance
- for fixed and portable gas stations
- pressure gauge diameter 50mm
- inlet pressure up to 200bar
- safety valve
- coloured according to the gas type
- easily serviced
- low price
- 12-month warranty

Seria "mini"

- lekka waga, mały rozmiar z dobrą wydajnością
- do stacjonarnych i przenośnych stanowisk spawalniczych
- manometry o średnicy 50mm
- ciśnienie wejściowe do 200 barów
- zawór bezpieczeństwa
- kolor według rodzaju gazu
- łatwe w utrzymaniu
- niska cena
- 1 rok gwarancji

Item	Inlet connection	Outlet connection	Country	Order No.
RAr/CO-200DM mini	W21,8 x 1/14" DIN 477 No. 6	G1/4, 6E	Poland, Bulgaria, Germany, Austria, Switzerland, Czech Republic, Slovakia, Hungary, Scandinavia	013.000.10
RAr-200DM mini	W24,32x1/14" DIN 477 No. 10 NEN3268 RU 3	G3/8, 6/9	Finland, Belgium, the Netherlands	013.000.13
RCO-200DM mini	W21.8 x 1/14" UNI 4406 NEN3268 RU 1	G3/8, 6/9	Finland, Italy, Belgium, the Netherlands	013.000.14
RAr-200DM mini	W24,5x1/14" UNI4412	G3/8, 6/9	Italy	013.000.15
RAr/CO-200DM mini	Ø21,7 x 1,814 N FE-29-650/C	12x100 D, 6	France	013.000.40
RAr-200DM mini	W24,32x1/14" NEN 3268 RU 3	G1/4, 6E	Belgium, Netherlands	013.000.44

	Inlet gas pressure (maximum): Ciśnienie wlotowe:	20 (200) MPa (bar)
	Maximum capacity at maximum working pressure: Znamionowa przepustowość:	
	- Ar	24 l/min (a) / 25 l/min (b)
	- CO ₂	22.5 l/min (a) / 25 l/min (b)

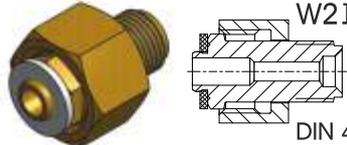
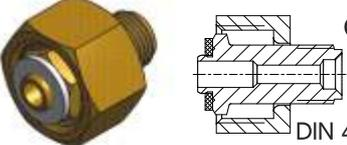
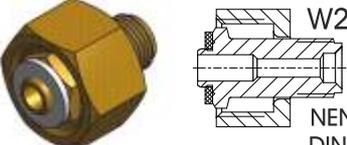
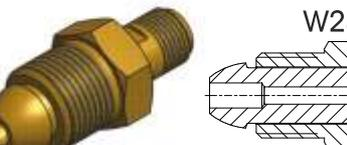

Item	Inlet connection	Outlet connection	Country	Order No.
RAr/CO-200DM RC	 W21,8x1/14" DIN 477 No.6	 6/9	Poland, Bulgaria, Germany, Austria, Switzerland, Serbia, Czech Republic, Slovakia, Hungary, Scandinavia, Romania	065.000.00
RAr/CO-200DM RC	 G3/4 DIN 477 No.9	 6/9	Lithuania, Latvia, Estonia, Slovakia	065.000.01
RAr/CO-200DM RC	 W24,32 NEN3268 RU 3 DIN 477 No.10	 6/9	Belgium, Netherlands, Finland	065.000.02
RAr/CO-200DM RC	 W24,5x1/14" UNI4412	 G ³ / ₈ , 6/9	Italy	065.000.03

Universal flow regulator | RAr/CO-200V DM | Reduktor butlowy do argonu i dwutlenku węgla

	Inlet gas pressure (maximum): Ciśnienie wlotowe:	20 (200) MPa (bar)
	Maximum capacity: Znamionowa przepustowość:	
	- Ar	24 l/min
	- CO ₂	22.5 l/min
	Weight, no more than Waga:	0.9 kg

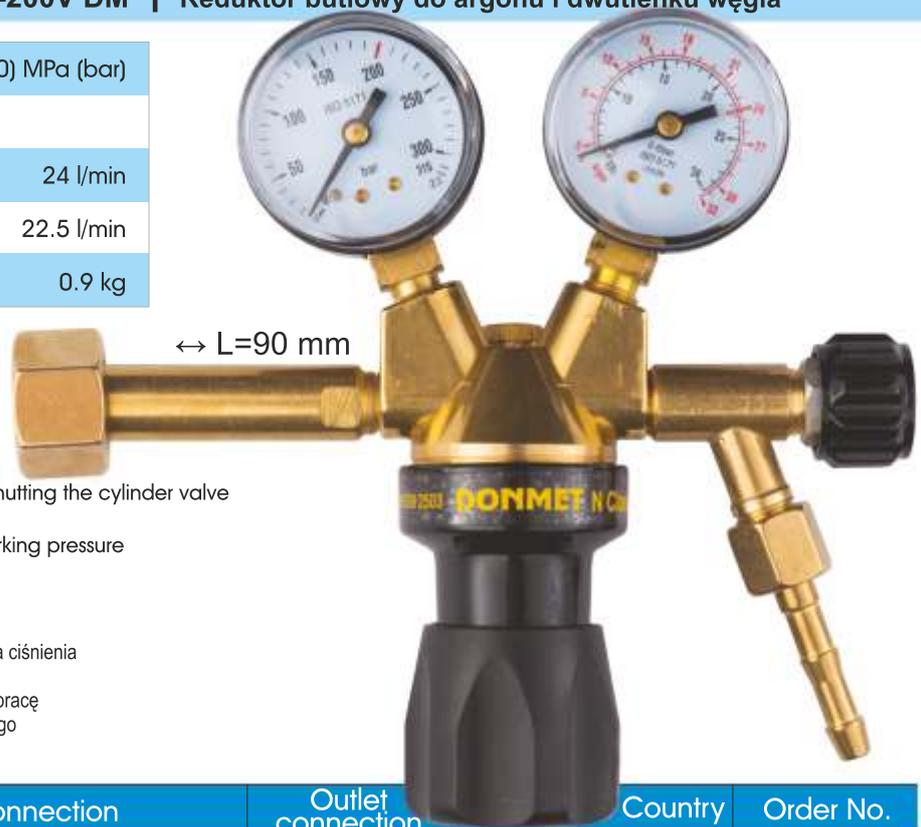

“Vertical” series

- shut-off valve at the outlet allows you to maintain the pressure setting during work intervals without shutting the cylinder valve
- durable reducing unit ensures fault-free operation
- convenient knob allows you to easily adjust the working pressure
- 3-year warranty

Seria “pionowe”

- Zawór odcinający na wylocie umożliwia utrzymanie ustawienia ciśnienia podczas przerw w działaniu, bez blokowania zaworu na butli
- Wytrzymała jednostka redukująca zapewnia bezproblemową pracę
- wygodny zawór pozwala na łatwą regulację ciśnienia roboczego
- 3 lata gwarancji

Item	Inlet connection	Outlet connection	Country	Order No.
RAr/CO-200V DM	 W21,8 x 1/14" DIN 477 No. 6	 G1/4, 6E	Poland, Bulgaria, Germany, Austria, Switzerland, Czech Republic, Slovakia, Hungary, Scandinavia	059.000.09
RAr/CO-200V DM	 G3/4 DIN 477 No. 9	 G1/4, 6E	Lithuania, Latvia, Estonia, Ukraine	059.000.07
RAr-200V DM	 W24,32x1/14" DIN 477 No. 10 NEN3268 RU 3	 G3/8, 6/9	Finland, Belgium, the Netherlands	059.000.30
RCO-200V DM	 W21,7x1/14" W21,8x1/14" UNI 4406 NEN3268 RU 1	 G3/8, 6/9	Finland, Italy, Belgium, the Netherlands	059.000.20
RAr-200V DM	 W24,5x1/14" UNI4412	 G3/8, 6/9	Italy	059.000.32
RAr/CO-200V DM	 W21,8x1/14" DIN 477 No. 6	 M16x1,5, 6/9	Greece	059.000.34
RAr/CO-200V DM	 Ø21,7x1,814 N FE-29-650/C	 12x100 D, 6	France	059.000.40

Universal flow regulator | RAr/CO-200-4 DM | Reduktor butlowy do argonu i dwutlenku węgla

	Inlet gas pressure (maximum): Ciśnienie wlotowe:	20 (200) MPa (bar)
	Maximum capacity: Znamionowa przepustowość:	
	- Ar	24 l/min
	- CO ₂	22.5 l/min
	Weight, no more than: Waga:	1.3 kg

- highest performance
- large membrane ensures accurate maintenance of working pressure when the cylinder pressure drops
- pressure gauges Ø63mm according to ISO 5171
- reliable reducing unit
- inlet pressure up to 200bar
- safety valve
- coloured according to the type of gas
- durable
- 3-year warranty

- najwyższa wydajność
- duża membrana zapewnia precyzyjne utrzymywanie ciśnienia roboczego, gdy ciśnienie w butle spada
- manometry o średnicy 63 mm zgodnie z ISO 5171
- niezawodna jednostka redukująca
- ciśnienie wejściowe do 200 barów
- zawór bezpieczeństwa
- kolor według rodzaju gazu
- długotrwały
- 3 lata gwarancji



Item	Inlet connection	Outlet connection	Country	Order No.
RAr/CO-200-4 DM	 DIN 477 No. 6	G1/4, 6E	Poland, Bulgaria, Germany, Austria, Switzerland, Czech Republic, Slovakia, Hungary, Scandinavia	039.000.10
RAr/CO-200-4 DM	 DIN 477 No. 9	M16x1,5, 6/9	Lithuania, Latvia, Estonia, Ukraine	039.000.11
RAr/CO-200-4 DM	 DIN 477 No. 6	M16x1,5, 6/9	Lithuania, Latvia, Estonia, Ukraine	039.000.12
RAr-200-4 DM	 DIN 477 No. 10 NEN3268 RU 3	G3/8, 6/9	Finland, Belgium, the Netherlands	039.000.15
RCO-200-4 DM	 UNI 4406 NEN3268 RU 1	G3/8, 6/9	Finland, Italy, Belgium, the Netherlands	039.000.16
RAr-200-4 DM	 UNI4412 W24.51 1/14\"	G3/8, 6/9	Italy	039.000.17
RAr/CO-200-4 DM	 N FE-29-650/C	12x100 D, 6	France	039.000.40

 Inlet gas pressure (maximum):	20 (200) MPa (bar)
Ciśnienie wlotowe:	
Maximum capacity:	25 l/min
Znamionowa przepustowość:	
Weight, no more than	1.4 kg
Waga:	

-  - highest performance
- large membrane ensures accurate maintenance of working pressure when the cylinder pressure drops
- pressure gauges Ø63mm according to ISO 5171
- reliable reducing unit
- inlet pressure up to 200bar
- safety valve
- coloured according to the type of gas
- durable
- 3-year warranty

-  - najwyższa wydajność
- duża membrana zapewnia precyzyjne utrzymywanie ciśnienia roboczego, gdy ciśnienie w butle spada
- manometry o średnicy 63 mm zgodnie z ISO 5171
- niezawodna jednostka redukująca
- ciśnienie wejściowe do 200 barów
- zawór bezpieczeństwa
- kolor według rodzaju gazu
- długotrwały
- 3 lata gwarancji

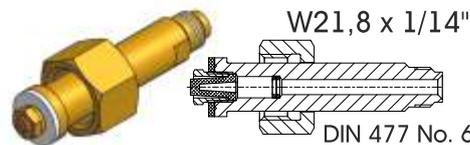
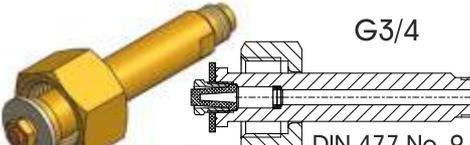
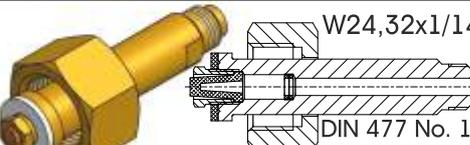
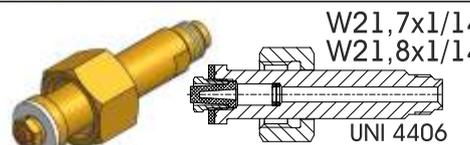
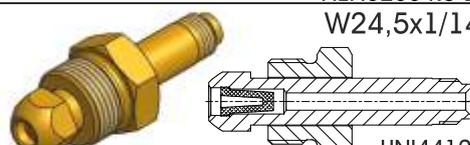
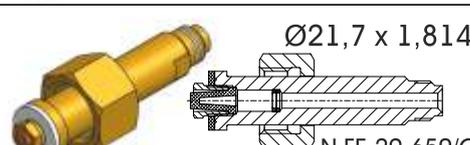

Item	Inlet connection	Outlet connection	Country	Order No.
RAr/CO-200-2 DM	 W21,8 x 1/14" DIN 477 No. 6	 G1/4, 6E	Poland, Bulgaria, Germany, Austria, Switzerland, Czech Republic, Slovakia, Hungary, Scandinavia	032.000.10
RAr/CO-200-2 DM	 G3/4 DIN 477 No. 9	 M16x1,5, 6/9	Lithuania, Latvia, Estonia, Ukraine	032.000.11
RAr-200-2 DM	 W24,32x1/14" DIN 477 No. 10 NEN3268 RU 3	 G3/8, 6/9	Finland, Belgium, the Netherlands	032.000.15
RCO-200-2 DM	 W21,7x1/14" W21,8x1/14" UNI 4406 NEN3268 RU 1	 G3/8, 6/9	Finland, Belgium, the Netherlands	032.000.16
RAr-200-2 DM	 W24,5x1/14" UNI4412	 G3/8, 6/9	Italy	032.000.17
RAr/CO-200-2 DM	 Ø21,7 x 1,814 N FE-29-650/C	 12x100 D, 6	France	032.000.40

	Inlet gas pressure (maximum): Ciśnienie wlotowe:	20 (200) MPa (bar)
	Maximum capacity: Znamionowa przepustowość:	25 l/min
	Weight , no more than Waga:	1.7 kg

- highest performance
- large membrane ensures accurate maintenance of working pressure when the cylinder pressure drops
- pressure gauges Ø63mm according to ISO 5171
- reliable reducing unit
- inlet pressure up to 200bar
- safety valve
- coloured according to the type of gas
- durable
- 3-year warranty

- najwyższa wydajność
- duża membrana zapewnia precyzyjne utrzymywanie ciśnienia roboczego, gdy ciśnienie w butle spada
- manometry o średnicy 63 mm zgodnie z ISO 5171
- niezawodna jednostka redukująca
- ciśnienie wejściowe do 200 barów
- zawór bezpieczeństwa
- kolor według rodzaju gazu
- długotrwały
- 3 lata gwarancji



Item	Inlet connection	Outlet connection	Country	Order No.
RAr/CO-200-2 DM	 W21,8 x 1/14" DIN 477 No. 6	 G1/4, 6E x2	Poland, Bulgaria, Germany, Austria, Switzerland, Czech Republic, Slovakia, Hungary, Scandinavia	032.000.20
RAr-200-2 DM	 W24,32x1/14" DIN 477 No. 10 NEN3268 RU 3	 G3/8, 6/9 x2	Finland, Belgium, the Netherlands	032.000.24
RCO-200-2 DM	 W21,7x1/14" W21,8x1/14" UNI4406 NEN3268 RU 1	 G3/8, 6/9 x2	Italy, Belgium, the Netherlands	032.000.26
RAr-200-2 DM	 W24,5x1/14" UNI4412	 G3/8, 6/9 x2	Italy	032.000.25
RAr/CO-200-2 DM	 Ø21,7x1,814 N FE-29-650/C	 12x100 D, 6 x2	France	032.000.41

Universal flow regulator | DONMET RAr/CO-200DM RC | Reduktor butlowy do argonu i dwutlenku węgla

	Inlet gas pressure (maximum):	20 (200) MPa (bar)
	Ciśnienie wlotowe:	20 (200) MPa (bar)
	Maximum capacity at maximum working pressure:	
	Znamionowa przepustowość:	
	- Ar	24 l/min (a) / 25 l/min (b)
	- CO ₂	22.5 l/min (a) / 25 l/min (b)



Item	Inlet connection	Outlet connection	Country	Order No.
RAr/CO-200-2DM RC	 W21,8x1/14" DIN 477 No.6	 G $\frac{1}{4}$, 6	Poland, Bulgaria, Germany, Austria, Switzerland, Serbia, Czech Republic, Slovakia, Hungary, Scandinavia, Romania	065.000.20
RAr/CO-200-2DM RC	 G3/4 DIN 477 No.9	 G $\frac{1}{4}$, 6	Lithuania, Latvia, Estonia, Slovakia	065.000.21
RAr/CO-200-2DM RC	 W24,32x1/14" NEN3268 RU 3 DIN 477 No.10	 G $\frac{3}{8}$, 6/9	Belgium, Netherlands	065.000.24

FLOWMETER 25 Ar/CO₂ | ROTAMETR 25 Ar/CO₂

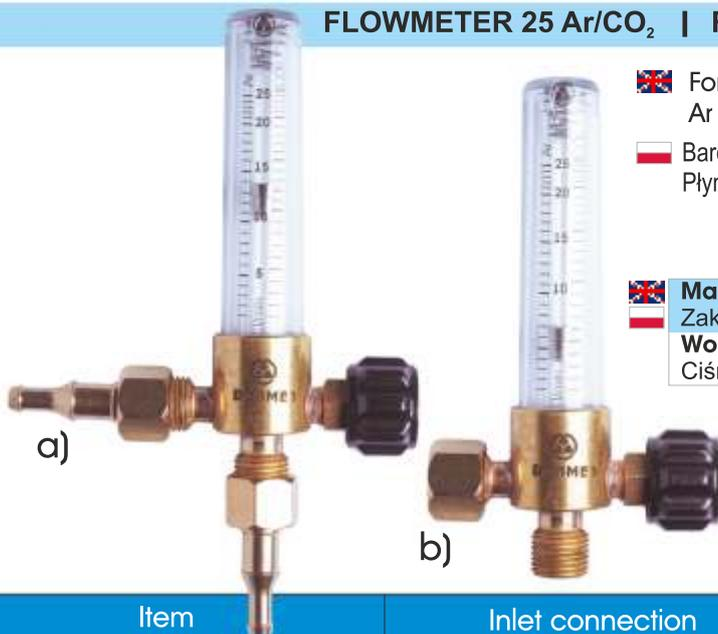

For regulation and control of shielding gases Ar and CO₂ consumption

Bardzo dokładny i niezawodny. Płynna regulacja gazu umożliwia precyzyjne ustawienie

	Maximum value of consumption::	25 l/min
	Zakres przepustowości:	
	Working pressure:	3,5 bar
	Ciśnienie robocze:	

Item	Inlet connection	Outlet connection (hose)	Order No.
a) FLOWMETER 25 Ar/CO ₂	Connector ext. M16x1,5	Connector ext. M16x1,5	013.200.24
b) FLOWMETER 25 Ar/CO ₂	Nut int. M16x1,5	Connector ext. M16x1,5	013.200.21
b) FLOWMETER 25 Ar/CO ₂	Nut int. G1/4	Connector ext. G1/4	013.200.15
b) FLOWMETER 25 Ar/CO ₂	Nut int. G3/8	Connector ext. G3/8	013.200.29

Pressure regulators for | FORMIER 10 | Regulatory ciśnienia dla

FORMIER® 10 is a two-component mixture comprising 90% nitrogen and 10% hydrogen. One of the most popular purging gases in Europe. It is used on austenitic stainless steels.

FORMIER® 10 jest dwuskładnikową mieszaniną zawierającą 90% azotu i 10% wodoru. Jeden z najpopularniejszych gazów oczyszczających w Europie. Stosowany jest na austenitycznych stalach nierdzewnych.

FORMIER® 10
(90%N₂+10%H₂)



RNH-200-4DM FORMIER10



RNH-200-2DM FORMIER10

Item	Inlet connection	Outlet connection	Order No.
RNH-200-2DM FORMIER10	<p>W21.8x1/14" LH DIN 477 No. 1</p>	<p>G3/8LH, 6/8</p>	032.000.19
RNH-200-4DM FORMIER10	<p>W21.8x1/14" LH DIN 477 No. 1</p>	<p>G3/8LH, 6/8</p>	039.000.19

Pressure regulators for 300 bar | NEVOC System | Reduktory butlowe 300 bar

The pressure regulators for 300 bar cylinders with international valve outlet W30x2



RO-300-2 DM



RAR-300-4 DM
RN-300-4 DM

Item	Inlet connection	Outlet connection (hose)	Order No.
RO-300-2 DM	W30x2 (D38) (18,7/17,3) BS 341-3 fig.15 No.32	G1/4 (6)	044.000.31
RAR-300-4 DM	W30x2 (D38) (20,1/15,9) BS 341-3 fig.15 No.32	G1/4 (6)	039.000.31
RN-300-4 DM	W30x2 (D38) (20,1/15,9) BS 341-3 fig.15 No.32	G1/4 (6)	039.000.33

DEVICE FOR SAVING AND CONTROLLING THE FLOW OF CARBON DIOXIDE/ARGON/GAS MIXTURES

Most regulators for MIG/MAG/TIG welding are set for the working pressure of 3,5-6 bar with the gas consumption of up to 32 l/min. "Optimizer DM" provides necessary protection of the welding pool at the pressure of 0,8 bar with the same consumption of 32 l/min. It allows to save up to 50% of gas.

- ▶ to be installed at the outlet connection of the regulator;
- ▶ saves up to 50% of shielding gas (see table below);
- ▶ reduces the frequency of changing the cylinders;
- ▶ reduces the cost of cylinders' transportation to gas stations;
- ▶ saves money for gas purchasing.

URZĄDZENIE DO OSZCZĘDZANIA I OPTIMALNEGO ZUŻYCIA CO₂/ARGONU/MIESZANKI GAZÓW

Większość reduktorów do spawania MIG / MAG / TIG jest ustawiona na ciśnieniu robocze 3,5-6 bar, z przepływem gazu do 32 l/min. "OPTIMIZER DM" zapewnia niezbędną ochronę jeziorka spawalniczego przy ciśnieniu 0,8 bara, przy tym samym natężeniu przepływu - 32 l / min. Pozwala to zaoszczędzić do 50% gazu.

- ▶ jest montowany na złączu wyjściowym reduktora;
- ▶ oszczędza do 50% gazu osłonowego (patrz tabela poniżej);
- ▶ zmniejsza częstotliwość wymiany butle;
- ▶ zmniejsza koszt transportu butle;
- ▶ zmniejsza koszty zakupu gazu.

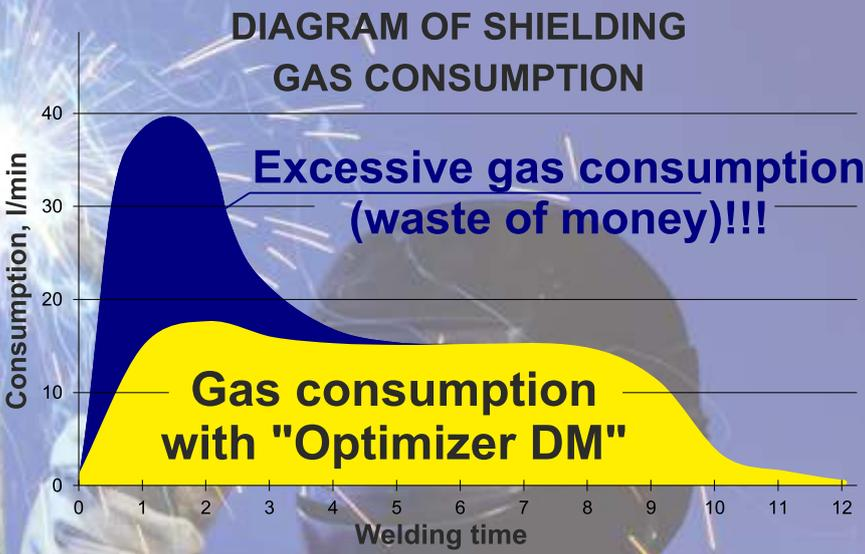

Item	Order No.
"Optimizer DM" Lite G3/8	045.000.04
"Optimizer DM" Lite G1/4	045.000.05



Every 3rd cylinder is free

- Advantages of "Optimizer DM":**
- optimum shielding gas flow from the very beginning;
 - no turbulent splash at the beginning of welding;
 - twice more seams with the same amount of gas.

- "Optimizer DM" zapewnia:**
- optymalny przepływ gazu ochronnego od pierwszych sekund;
 - nie ma turbulencji na początku spawania;
 - dwa razy więcej spoin dla tej samej ilości gazu

Annual economy of shielding gas depending on welding mode / Roczna oszczędność gazu ochronnego w zależności od trybu spawania

Gas consumption	50% (Spot)	30% (short seams)	18% (long seams)
10 cylinders/month	60	36	22
5 cylinders/month	30	18	11
2 cylinders/month	12	8	5

Helium regulator for inflating balloons | RHe-200DM mini | Helowy regulator do pompowania balonów



	Maximum capacity:	50 m ³ /h
	Nominalna przepustowość:	50 m ³ /h
	Maximum gas inlet pressure:	200 bar
	Ciśnienie wlotowe:	200 bar
	Maximum gas working pressure:	12.5 bar
	Ciśnienie wylotowe:	12.5 bar
	Weight, no more than:	0.78 kg
	Waga:	0.78 kg

Item	Inlet connection	Outlet connection	Order No.
RHe-200DM mini	G3/4	G $\frac{1}{4}$, for a flexible hose with a gun	048.000.06
RHe-200DM mini	G3/4	M16x1,5 Ball inflation valve	048.000.07
RHe-200DM mini	W21.8x1/14"	M16x1,5 Ball inflation valve	048.000.08

Nitrogen pressure regulator | RN-250DM | Reduktor do azotu

	Inlet gas pressure (maximum):	250 bar
	Ciśnienie wlotowe:	250 bar
	Maximum gas working pressure:	90 bar
	Zakres ciśnień wylotowych:	90 bar
	Maximum capacity:	155 m ³ /h
	Znamionowa przepustowość:	155 m ³ /h
	Weight, no more than:	2.1 kg
	Waga:	2.1 kg



Item	Inlet connection	Outlet connection	Country	Order No.
RN-250DM	 W24,32x1/14" DIN 477 No. 10	 G3/8, 8E	Finland	053.000.05
RN-250DM	 Ø21,7x1,814 N FE-29-650/C	 16x150 D, 10	France	053.000.40
RN-250DM	 G3/4 DIN 477 No. 9	 G1/4, 6	Poland, Bulgaria, Germany, Austria, Switzerland, Czech Republic, Slovakia, Hungary, Romania, Scandinavia, Finland, Ukraine, Lithuania, Latvia, Estonia	053.000.10
RN-250DM	 G3/4 DIN 477 No. 9	 G3/8, 6/8		053.000.11

Specialy designed for industrial and laboratory gas tapping points (open gas stations) for quick installation.

- versions for oxygen, acetylene, propane, carbon dioxide and argon
- a special version for industrial and laboratory use
- convenient and easy connection to tapping points
- precise pressure adjustment and control
- reliable reducing valve with a PU insert
- vertical positioning of the knob ensures the welder's safety
- the pressure gauge scale faces the operator for easy observance of readings

Specjalnie zaprojektowany do przemysłowych i laboratoryjnych punktów poboru gazu (otwarte stacje gazowe) do szybkiego montażu.

- wersje dla tlenu, acetylenu, propanu, dwutlenku węgla i argonu
- specjalna wersja do użytku przemysłowego i laboratoryjnego
- wygodne i łatwe połączenie z punktami spustowymi
- precyzyjna regulacja i kontrola ciśnienia
- niezawodny zawór redukcyjny z wkładką PU
- pionowe ustawienie pokrętki zapewnia bezpieczeństwo spawacza
- skala manometru skierowana jest w stronę operatora w celu łatwej obserwacji odczytów

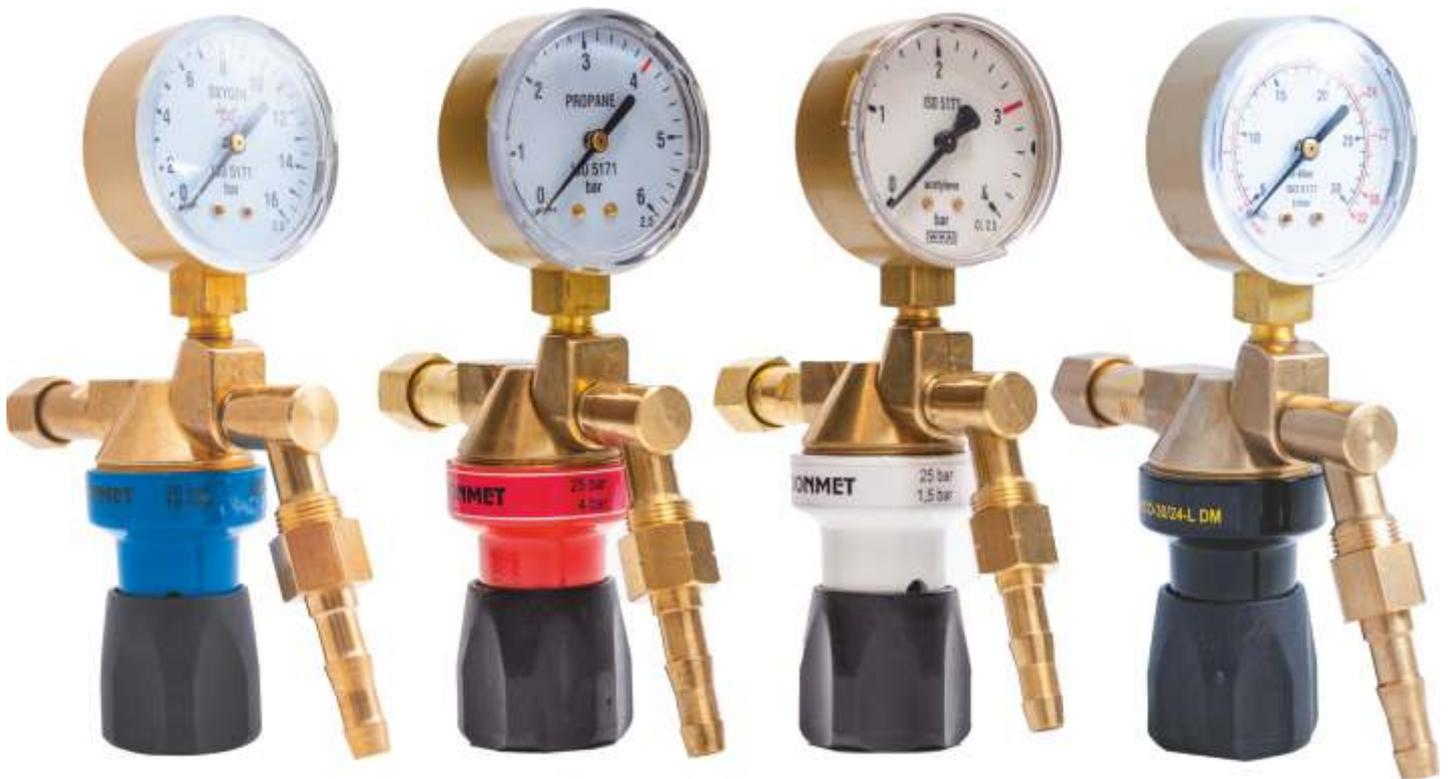

RO-10/10-L DM

RP-6/4-L DM

RA-10/1,5-L DM

RAr/CO-30/24-L DM

Item	Max. inlet pressure, bar	Max. outlet pressure, bar	Capacity	Inlet connection	Outlet connection (hose)	Order No.
RO-10/10-L DM	30	10	10 m ³ /h	Nut int.G3/8	Connector ext. G3/8 (8)	071.000.00
RP-6/4-L DM	25	4	6 m ³ /h	Nut int.G3/8LH	Connector ext. G3/8 LH (8)	076.000.00
RA-10/1,5-L DM	25	1,5	10 m ³ /h	Nut int.G3/8LH	Connector ext. G3/8 LH (8)	074.000.00
RAr/CO-30/24-L DM	30	-	Ar-32 l/min	Nut int.G3/8	Connector ext. G3/8 (8)	075.000.00
RAr/CO-30/24-L DM	30	-	CO ₂ -30 l/min	Nut int.G3/8	Connector ext. G1/4 (6)	075.000.01



- Nitrogen pressure regulators with increased capacity** for testing pressurized systems with compressed nitrogen (e.g. refrigeration / air conditioning systems, etc.)
 - high capacity 100m³/h
 - shut-off valve at the outlet
 - safety valve

- do testowania układów ciśnieniowych sprężonym azotem (np. systemy chłodnicze / klimatyzacyjne itp.)
 - wysoka wydajność 100 m³ / h
 - zawór odcinający na wylocie
 - zawór bezpieczeństwa



Nipple for refrigerant hose 1/4" SAE (Freon R22, R134) 962.065.00

Nipple for refrigerant hose 5/16" SAE (Freon R410) 962.065.01

Gas type	Max inlet pressure	Working pressure	Capacity
Nitrogen	200 bar	0-30 bar	100 m ³ /h
Oxygen	200 bar	0-20 bar	80 m ³ /h

Item	Inlet connection	Outlet connection	Country	Order No.
RN-200-V DM (nitrogen)	W24,32x1/14" DIN 477 No. 10	G1/4, 6	Poland, Bulgaria, Germany, Austria, Switzerland, Czech Republic, Slovakia, Hungary, Scandinavia, Romania, Finland	057.000.20
RN-200-V DM (nitrogen)	G3/4 DIN 477 No. 9	G1/4, 6	Poland, Bulgaria, Germany, Austria, Switzerland, Czech Republic, Slovakia, Hungary, Scandinavia, Romania, Finland	057.000.25
RN-200-V DM (nitrogen)	W21.8x1/14" DIN 477 No. 6	G1/4, 6	Poland, Bulgaria, Germany, Austria, Switzerland, Czech Republic, Slovakia, Hungary, Scandinavia, Romania, Finland	057.000.26
RN-200-V DM (nitrogen)	Ø21,7x1,814 N FE 29-650/C	16x150 D, 10	France	057.000.40
BAZO-150 DM GOST (nitrogen)	G3/4 DIN 477 No. 9	M16x1,5, 6/9	Ukraine, Lithuania, Latvia, Estonia	057.000.30
RO-200/30-V DM (oxygen)	G3/4 DIN 477 No. 9	G3/8, 6/8	Poland, Bulgaria, Germany, Austria, Switzerland, Czech Republic, Slovakia, Hungary, Scandinavia, Romania, Finland	058.000.00



 Used for supplying and keeping up set working pressure in laboratory facilities, spectrometers, lasers, special equipment, during gas welding and cutting with high consumption and in other areas where high demands are placed on accurate pressure maintenance.

- two stages of pressure reduction
- accurate maintenance of set working pressure in the whole pressure range when supplying gas from the cylinder
- manual pressure relief valve
- resistant to frosting in case of high flow
- 2 safety valves

 Służy do dostarczania i utrzymania ustawionego ciśnienia roboczego w laboratoriach, spektrometrach, laserach, urządzeniach specjalnych, podczas spawania gazowego i cięcia o dużym zużyciu oraz w innych obszarach, w których wysokie wymagania dotyczą dokładnego utrzymania ciśnienia.

- dwa etapy redukcji ciśnienia
- dokładne utrzymanie ustawionego ciśnienia roboczego w całym zakresie ciśnienia przy podawaniu gazu z butli
- ręczny zawór bezpieczeństwa
- odporny na zamrażanie w przypadku dużego przepływu
- 2 zawory bezpieczeństwa

Item	Gas type	Inlet pressure, bar	Outlet pressure, bar	Inlet thread	Outlet thread	Order No.
2RO-200DM	Oxygen	200	0-8.0	G 3/4	G1/4 (6)	068.000.10
2RN-200DM	Nitrogen	200	0-8.0	W24,32x1/14"	G1/4 (6)	087.000.00
2RHe-200DM	Helium	200	0-8.0	W21,8x1/14"	G1/4 (6)	088.000.00
2RAr/CO-200DM	Argon, CO ₂	200	0-8.0	W21,8x1/14"	G1/4 (6)	089.000.00
2RAr/CO-200DM	Argon, CO ₂	200	0-8.0	W21,8x1/14"	G3/8 (6/9)	089.000.01



- ▶ 220 skilled professionals;
- ▶ 175 units of modern equipment and mechanical assembly manufacturing;
- ▶ research laboratory that is accredited by UkrSEPRO;
- ▶ more than 40,000 consumers;
- ▶ DONMET produces 80 types of equipment for gaseous oxygen cutting, welding, soldering, brazing, heating and thermal hardening;
- ▶ the plant produces and sells about 300,000 units of products per year!

⌘ DONMET Autogenous Equipment Plant Ltd. was founded in 1990.

Our company has been a player at the market of autogenous equipment for over 30 years. We produce different types of our own designed and patented equipment. Now DONMET is the largest manufacturer in Ukraine that designs and produces certificated equipment for cutting, brazing, welding and heating of metal, etc. Currently we have over 600 trade partners, and Equipment produced by DONMET is successfully used at many plants, coal mines and associations in Ukraine, Poland, Belarus, Moldova, Romania, Bulgaria, Greece, Italy, Hungary, Czech Republic, Portugal, Lithuania, Latvia, Estonia, Finland, Georgia, Kazakhstan, Uzbekistan, Iran.

As of 2017, we have a wholesale warehouse of finished goods in Poland which makes for fast and convenient delivery to DONMET customers across Europe.

All products are certified by UkrSEPRO according to ISO 9001-2015, Certificate No. UA006.SMST.0131-2019

Warranty period for the products is 12, 18 or 24 months.

DONMET solves difficult technical problems in the field of autogenous equipment.

As of 2017, we have a wholesale warehouse of finished goods in Poland which makes for fast and convenient delivery to DONMET customers across Europe.

All products are certified by UkrSEPRO according to

ISO 9001-2015,

Certificate No. UA006.SMST.0131-2019

Warranty period for the products is 12, 18 or 24

months.

DONMET solves difficult technical problems

in the field of autogenous equipment.

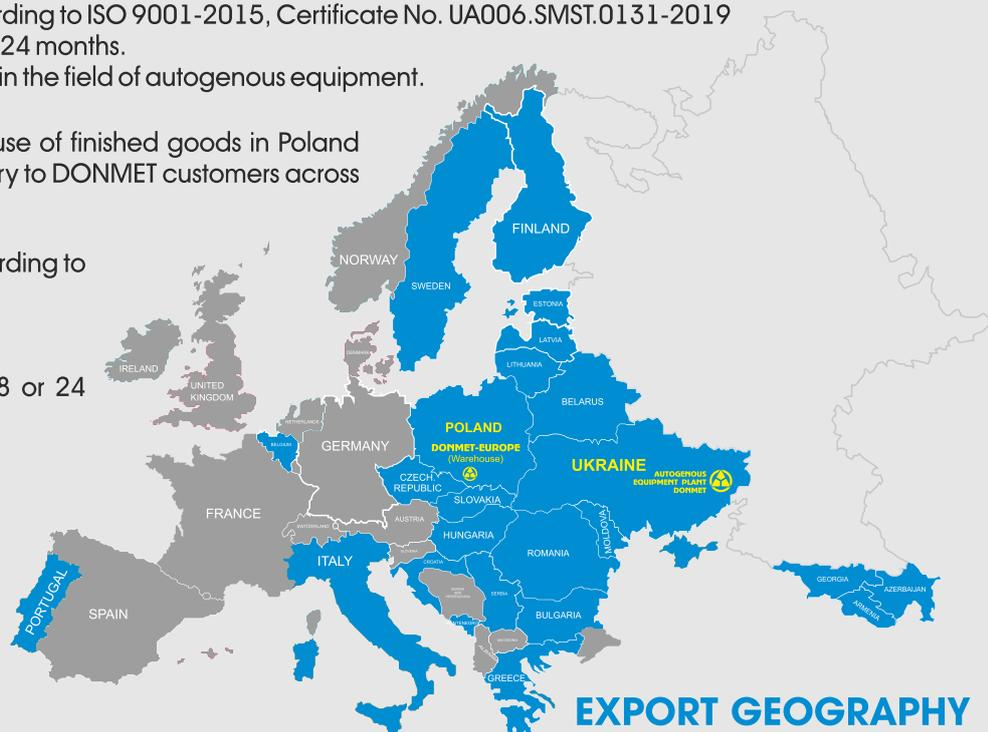

EXPORT GEOGRAPHY

CUTTING • WELDING • BRAZING



@DonmetTV



@zavod.donmet

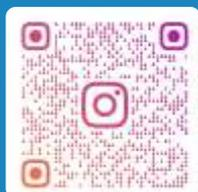

@zavoddonmet

Photo and design
Konstantin Brizhnichenko
www.fb.com/brizhnichenko

In the photo: Svetlana Melnik, Senior packer, Anna Alekseyenko, Engineer

FABRYKA SPRZĘTU GAZOWEGO SPAWALNICZEGO
DONMET®

DONMET-EUROPE sp.z o.o.
ul. Jedności 27, 43-100 Tychy, Polska
donmet.europe@gmail.com
www.donmet.com.pl
tel. +48733771236